

Treadwall® reed switch adjustment and replacement

See following pages for other models and troubleshooting.

Parts and Tools Needed:

1. 3/8" socket wrench
2. Cordless drill with phillips bit
3. Replacement reed switch if needed

Procedure:

1. Remove 1 or 2 panels
2. Rotate panel gap to reveal sprocket and sensor assembly on right or left side of the top shaft (depends on year). Older M4 models have it on the right-side pump sprocket. See next page.
3. Make sure that three magnets are present (2 -older M4 units). They should be equally spaced around the shaft with the flat face of the magnets facing up.
4. Inspect reed switch position, the tip should be 1/8 to 1/4 inch from magnets
5. If either the magnets or reed switch are misaligned make the adjustment and test the sensor by rotating the wall
6. If the reed switch needs to be replaced continue further
7. On newer units push sensor out of plastic clip and unplug from wire. Older units have a metal bracket as part of the sensor –

this will be replaced with the newer arrangements.

8. Plug new sensor in and make sure that it is adjusted 1/8 to 1/4 inch from the face of the magnets.
9. Test the new switch by rotating the wall and replace panel(s) if successful

Figures:

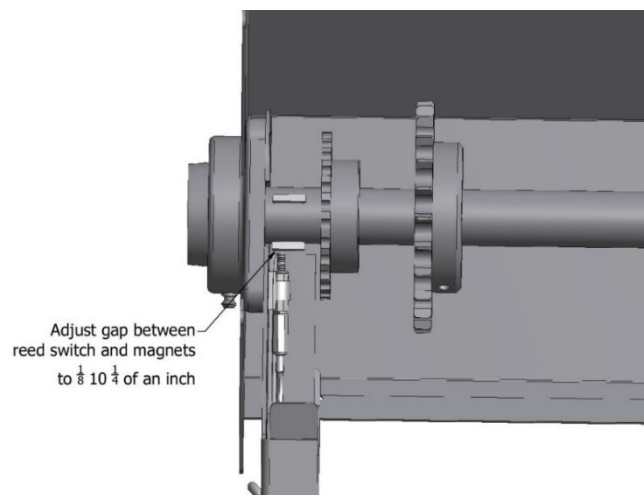
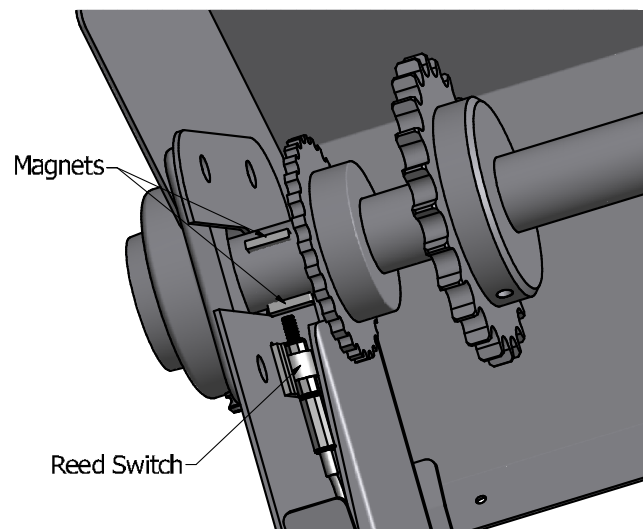

M4 reed switch adjustment and replacement

Parts and Tools Needed:

1. 3/8" socket wrench
2. Cordless drill with Philips bit
3. Reed switch/sensor

Procedure:

1. Remove 1 or 2 panels
2. Rotate panel gap to reveal sprocket and sensor assembly on right side of machine. Note: early M4 units have a bracket with the sensor facing the sprocket front (not shown) with the 2 magnets on the face
3. Inspect sprocket and make sure that two magnets are present, they should be close to the edge of the sprocket with the flat face of the magnet facing outwards
4. Inspect reed switch position, the tip should be 1/8 to 1/4 inch from both magnets
5. If either the magnets or reed switch are out of alignment, make the adjustment and test the sensor by rotating the wall
6. If the reed switch needs to be replaced continue further.
7. Push sensor out of plastic clip and unplug from wire. (If the unit has the older bracket, use the newer style to replace.)
8. Plug new sensor in and make sure that it is adjusted 1/8 to 1/4

inch from the face of the magnets.

9. Test the new switch by rotating the wall and replace panel(s) if successful

Figures:

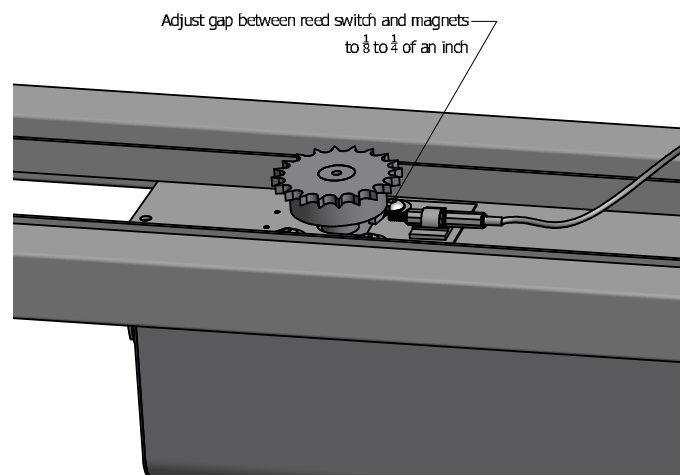
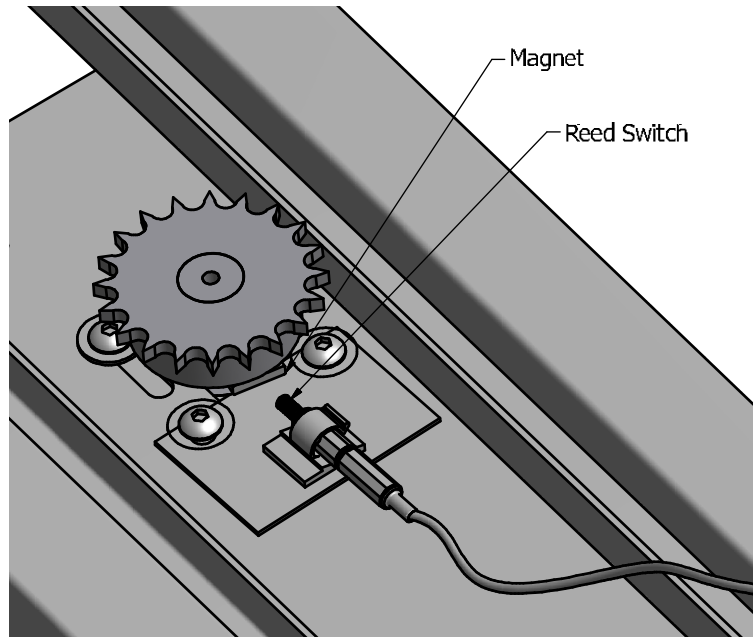

Troubleshooting issues with your reed switch sensors

Parts and Tools Needed:

(3) magnets

(1) spare sensor if needed

Tools to remove a panel if needed: 3/8" wrench and #2 Philips driver

Procedure:

If you are having an issue with getting the reed switch sensor to pick-up and register the magnets on your Treadwall or Laddermill, there is a number of things to check and some solutions.

1. First, make sure the display is working: once it is powered up you can gently wiggle the sensor plug in the back (male plug) to create a "distance count" on the display. This confirms display is working.
2. Second, working at the top unplug the sensor from the end of the sensor wire and by shorting out the male connector on the wire with a paperclip or screwdriver, recreate a "distance count" on the display verifying the wire is working.
3. Third, test the sensor itself by removing the sensor and wire from its plastic clip and waving the flat side a magnet along the side of the sensor/reed switch. This is the strongest orientation. This tests the complete set-up. By removing it from the clip, you can more accurately orient the magnet to the sensor.
4. If nothing works above, try replacing the sensor and testing it again by hand.
5. If the sensor works when waving a magnet by hand, but not on the shaft or sprocket, you can double up the magnets to create a stronger magnetic field. However, there is only one way to do this. See the image: you will need to place one magnet on top of the other, not side by side. They will only attach to each other in one orientation and with one side down. It is strongly recommended that a small amount of super glue be used between the magnets to ensure they stay together. You will have to re adjust the sensor to clear the extra height of the magnets - this is important! See image.

Figures:

