

LADDERMILL® Ascender

The Laddermill Ascender offers users the freedom of vertical training with intuitive and approachable movement. The simple operation takes the user into their training zone in minutes in a unique and challenging full body workout.

The ladder's rotation is powered by the climber's weight - there are no motors. The ladder angle is adjustable through a large range of angles. A simple auto stop system brakes the ladder when the user's feet reach the bottom rung, matching the ladder's movement to the user.

A lever adjusts speed or resistance and a display with time, distance and calories quantifies the workout, with goal setting options. A second lever adjusts the ladder angle which can be done while climbing. A small universal plug-in transformer (supplied) that can be plugged into any outlet is needed for the display.

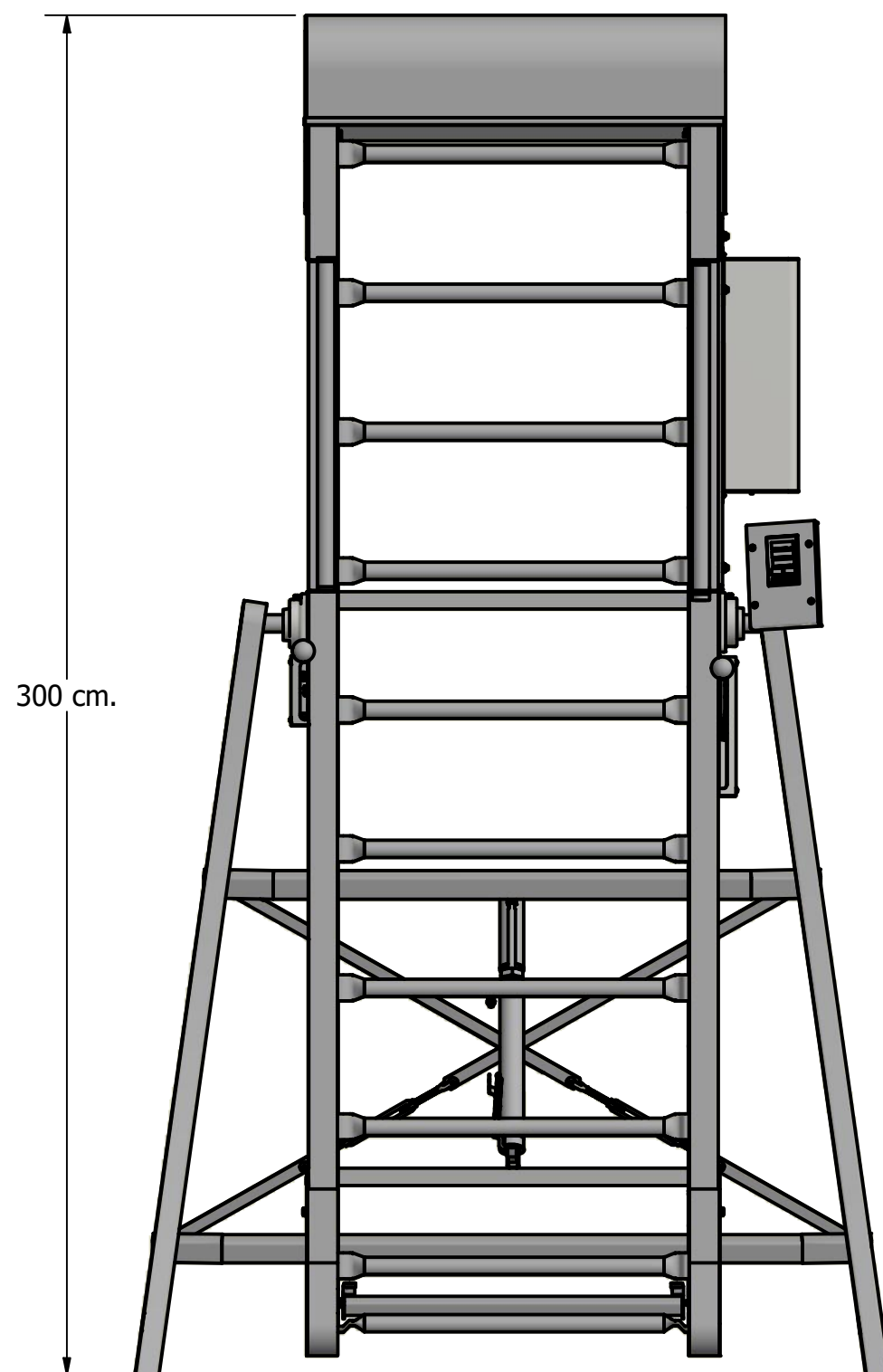
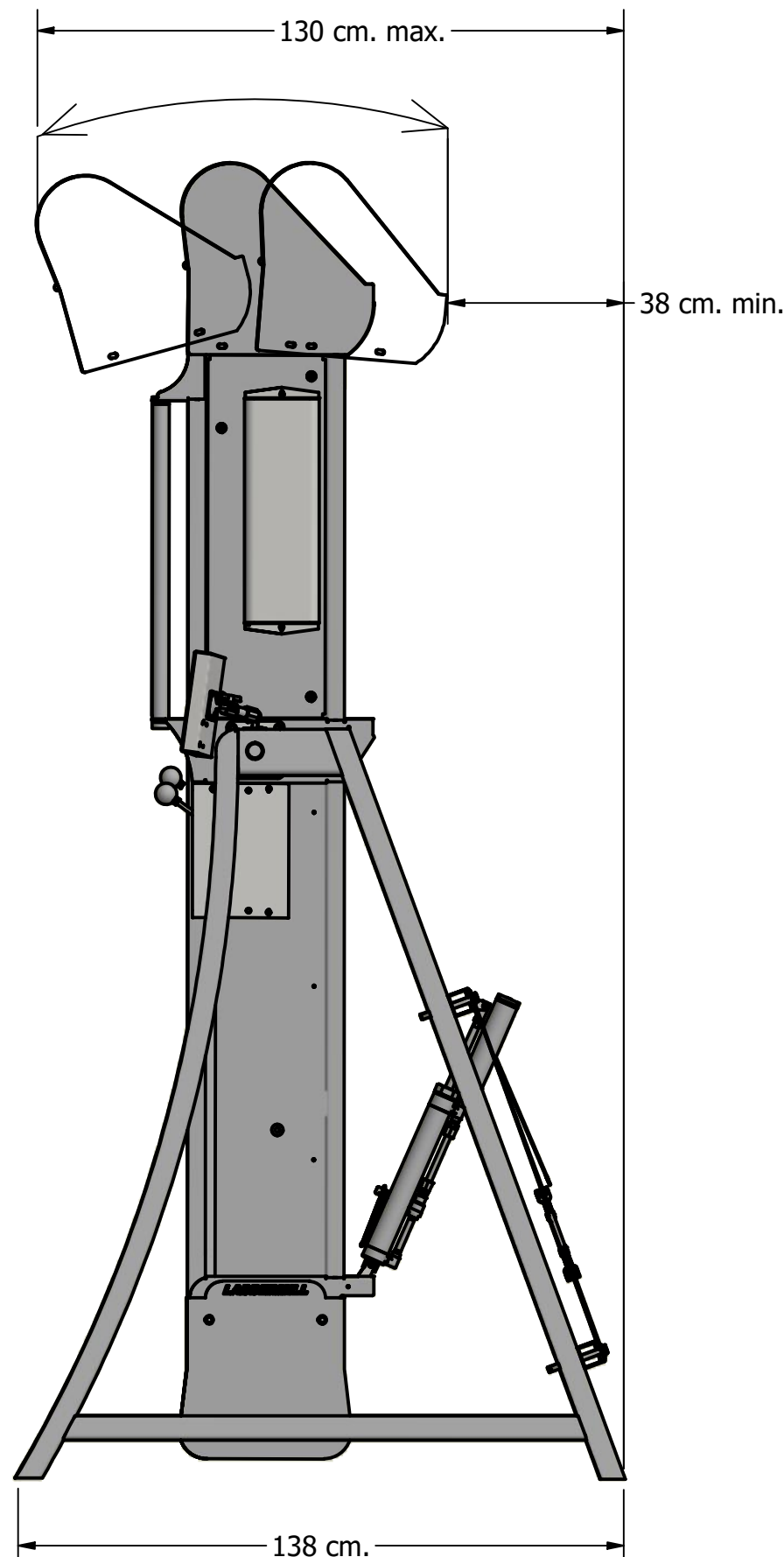
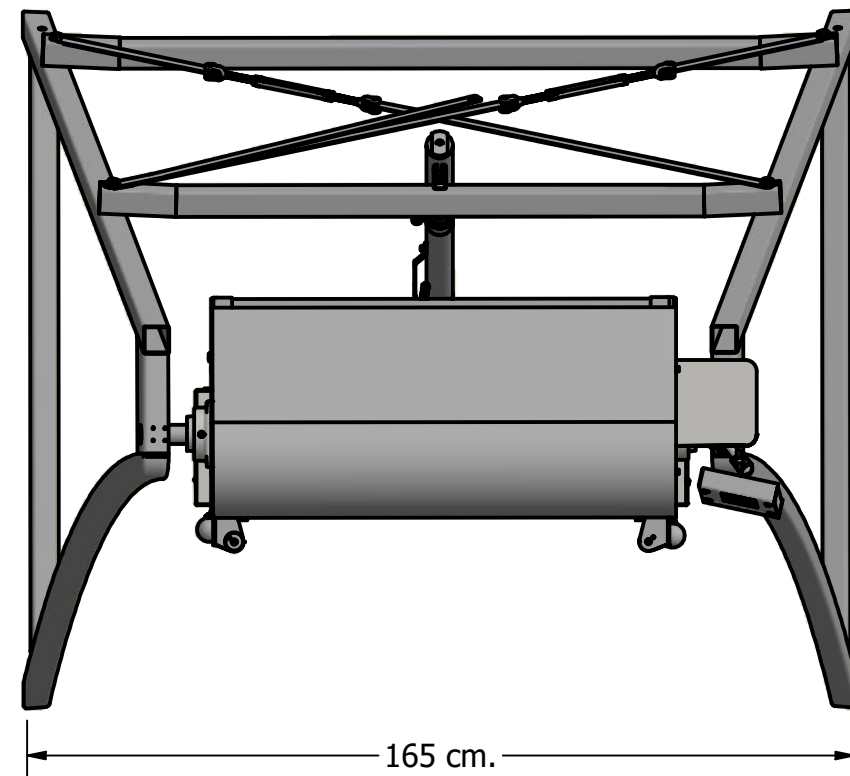
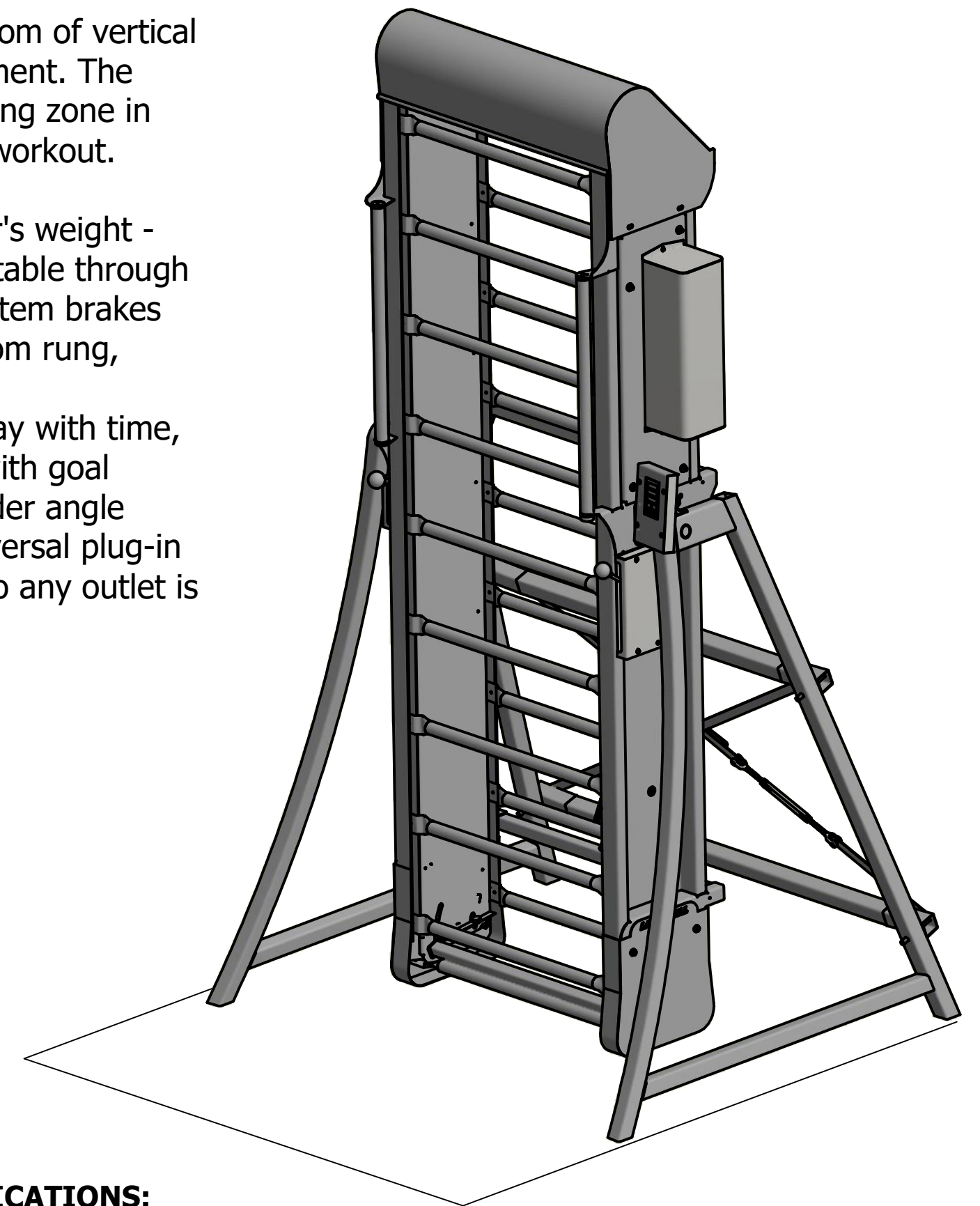

SPECIFICATIONS:

Specifications

Weight: 270 kg.

Construction: Steel framework with stainless steel rungs.

Placement: Indoor (outdoors with exterior upgrade).

Width of climbing rungs: 75 cm

Angle range: positive 5 degrees to negative 20 degrees (overhanging).

Mode of control: Hydraulic braking and resistance.

Electrical requirements: 9 VDC (1500ma) Plug-in transformer (supplied) - for display only

Electronic Display: Measures distance (feet or meters), time and calories. Time and distance goals can be pre-set.

Color - frame: Anthracite Gray. Custom colors available.

Warranty: 6 years on structural parts, 1 year electronics and labor. See full warranty for details.

METRIC