

Treadwall® V6/10 Rotating Walls

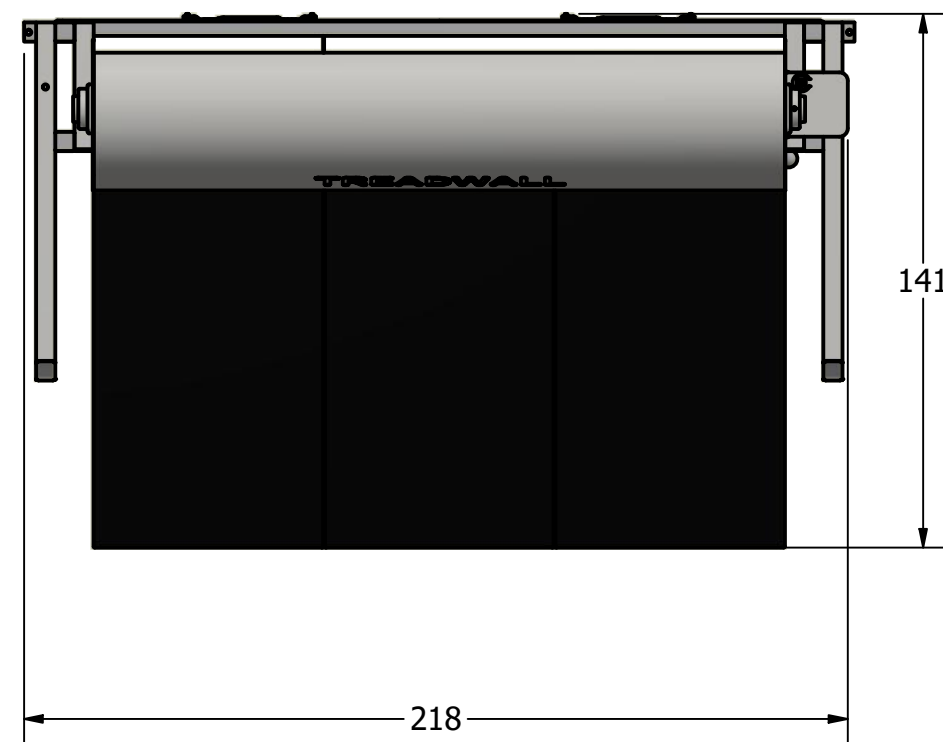

The Treadwall V6/10 is a vertical only design that offers full width and height climbing with the absolute minimal footprint. Although it is freestanding, it must be located against a building wall. The wall's rotation is powered by the climber's weight - no motors are used. A lever mounted on the right side adjusts the speed to suit the user, and a patented auto-stop^(tm) mechanism matches the movement of the wall to the climber's movements, gently braking when the climber's feet are at the bottom panel. The V6/10 is designed to fit under a 3 meter ceiling. See the V6/11 for higher ceilings. There is no V6/12 option.

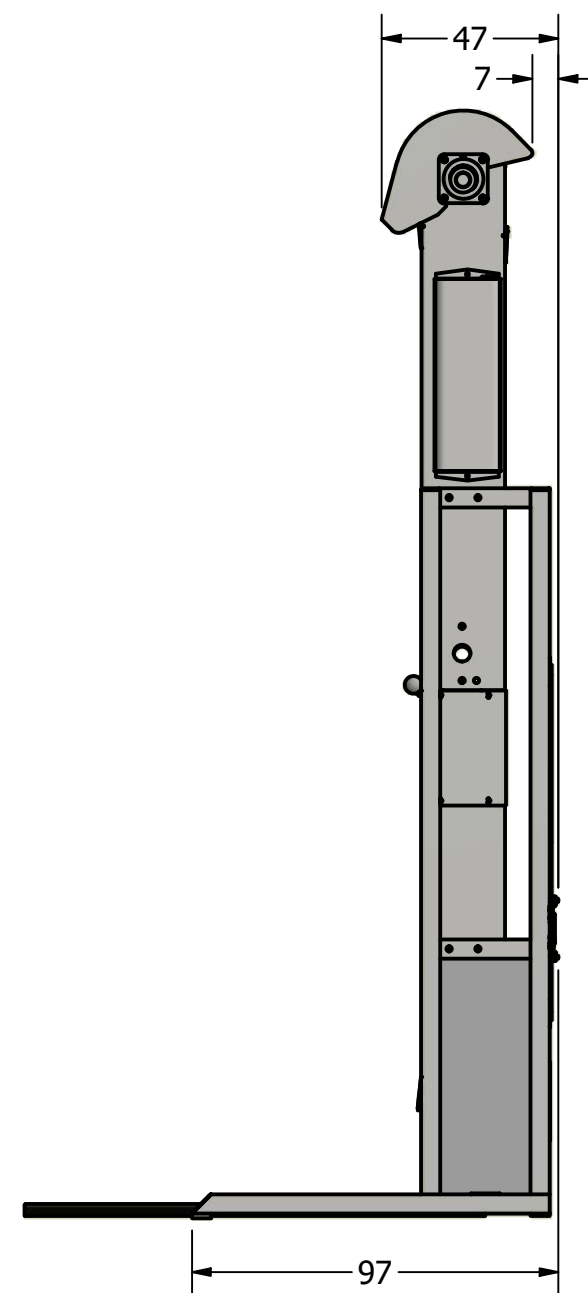
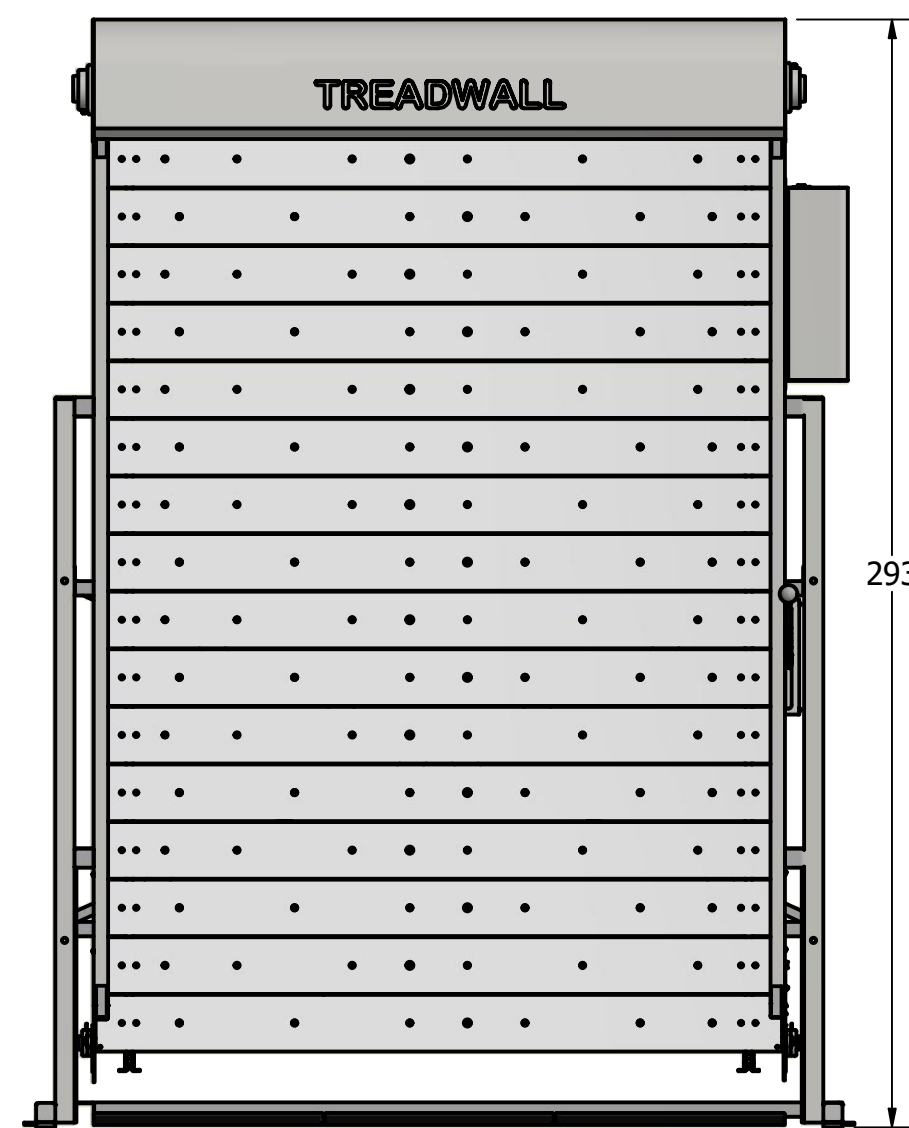
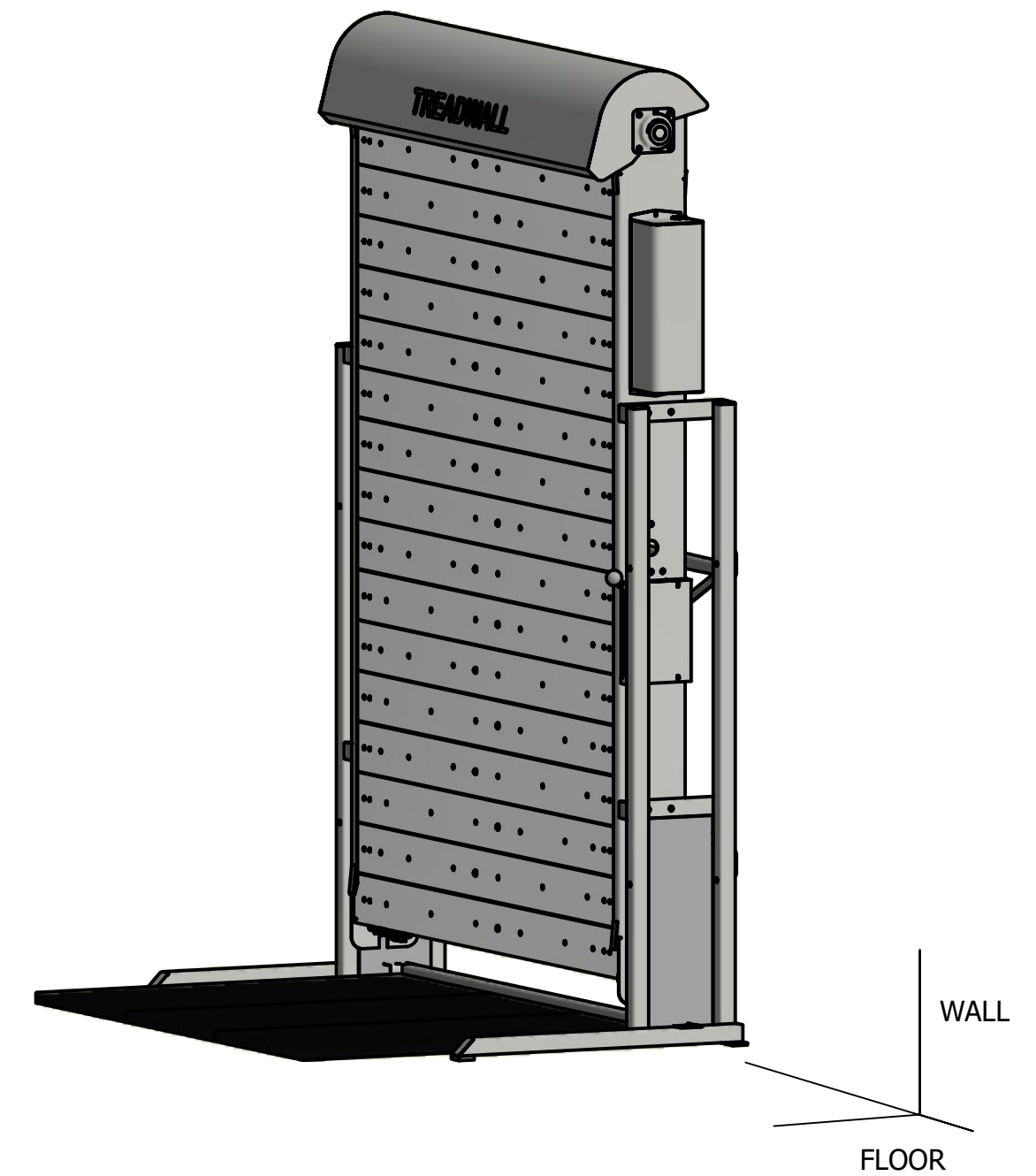

SPECIFICATIONS:

Weight: 408.6 kg.

Construction: Steel framework with custom-machined wood panels.

Placement: Inside standard - outside with exterior upgrade.

Width of climbing surface: 1.524 m.

Total length of climbing surface: 4.572 m.

Number of possible hold placements: 216.

Angle range: vertical only.

Mode of control: Electro-hydraulic braking and resistance.

Electrical requirements: 9 VDC (1500ma) Plug-in transformer (supplied) or battery used.

Electronic Display: Measures distance (feet or meters), time and calories.

Time and distance goals can be pre-set.

Color - frame: Anthracite Gray is standard. Custom colors available.

Color - panels: Natural Wood

Holds: Set of 45 custom training holds in 3 color groups, with optional 14 ladder Line^(tm) holds.

Maximum hold size: 6.35 cm high by 15.24 cm wide.

Floor Mat: 1.016 m x 1.524 m, 3.175 cm dual foam, black 14 oz. vinyl cover.

Warranty: Six years parts, one year electronics and labor.

See full warranty for details.

Treadwall® V6/11 Rotating Walls

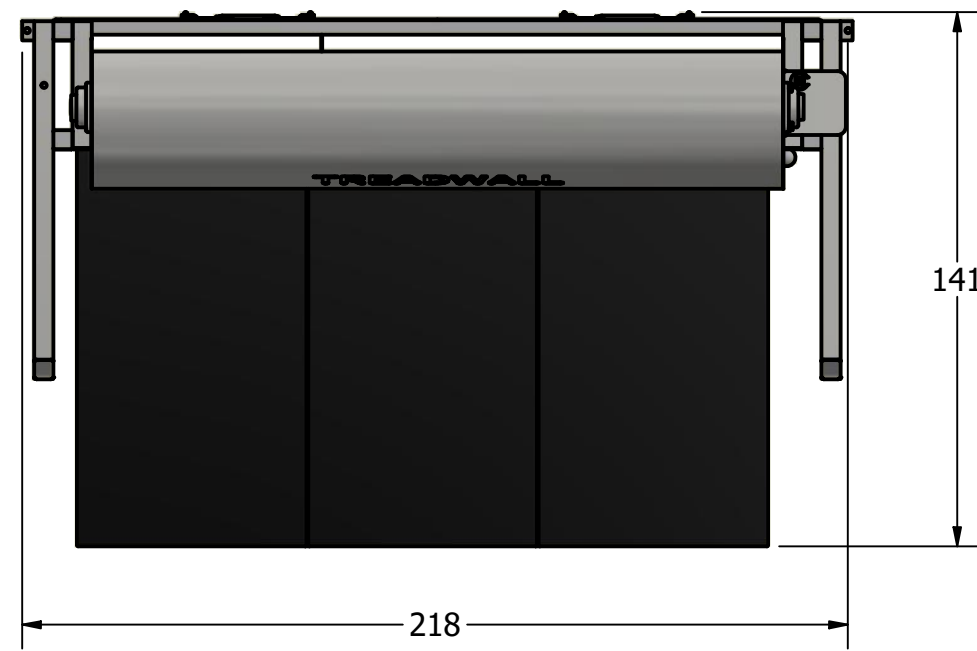

The Treadwall V6/11 is a vertical only design that offers full width and height climbing with the absolute minimal footprint. Although it is freestanding, it must be located against a building wall. The wall's rotation is powered by the climber's weight - no motors are used. A lever mounted on the right side adjusts the speed to suit the user, and a patented auto-stop^(tm) mechanism matches the movement of the wall to the climber's movements, gently braking when the climber's feet are at the bottom panel. The V6/11 is designed to fit under a 3.3 meter ceiling. See the V6/10 for lower ceilings. There is no V6/12 option.

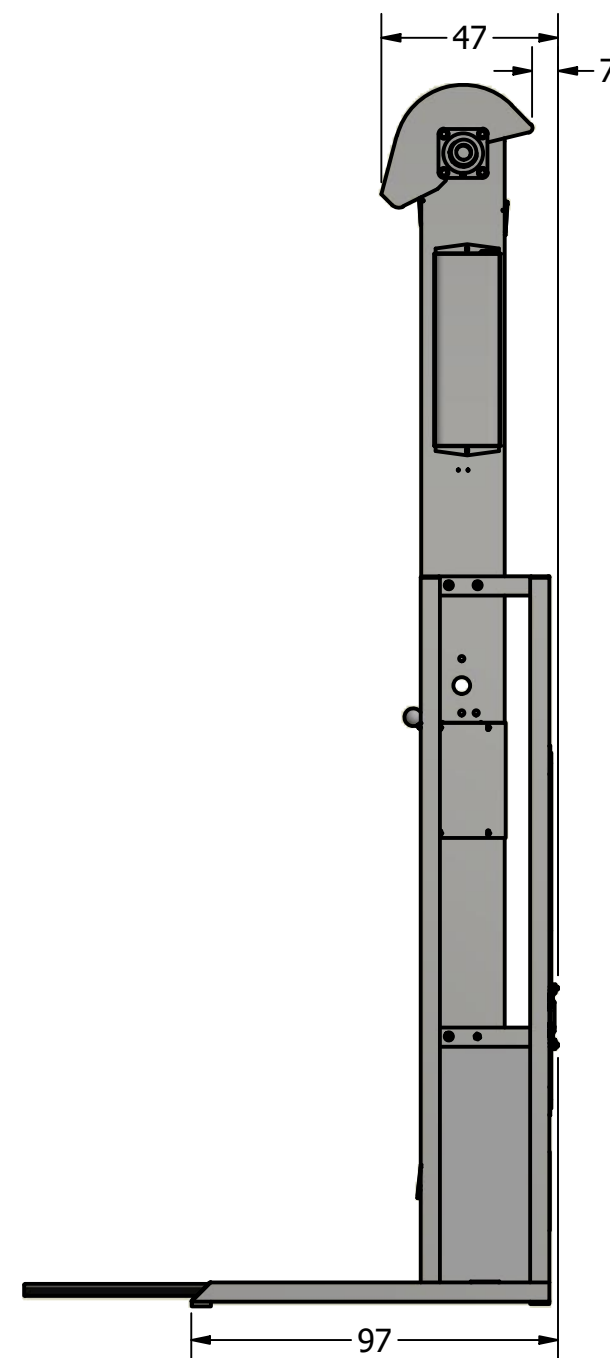
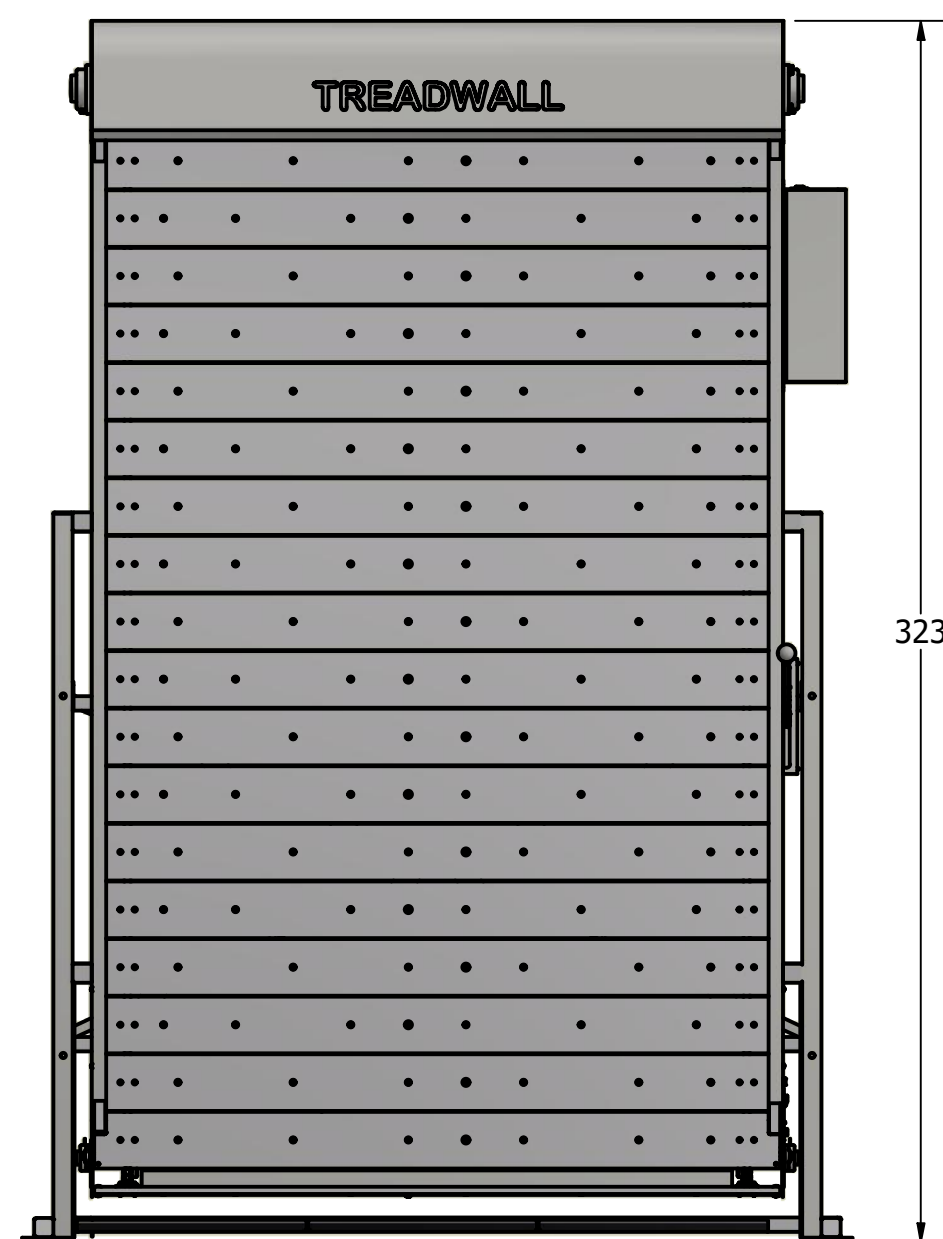
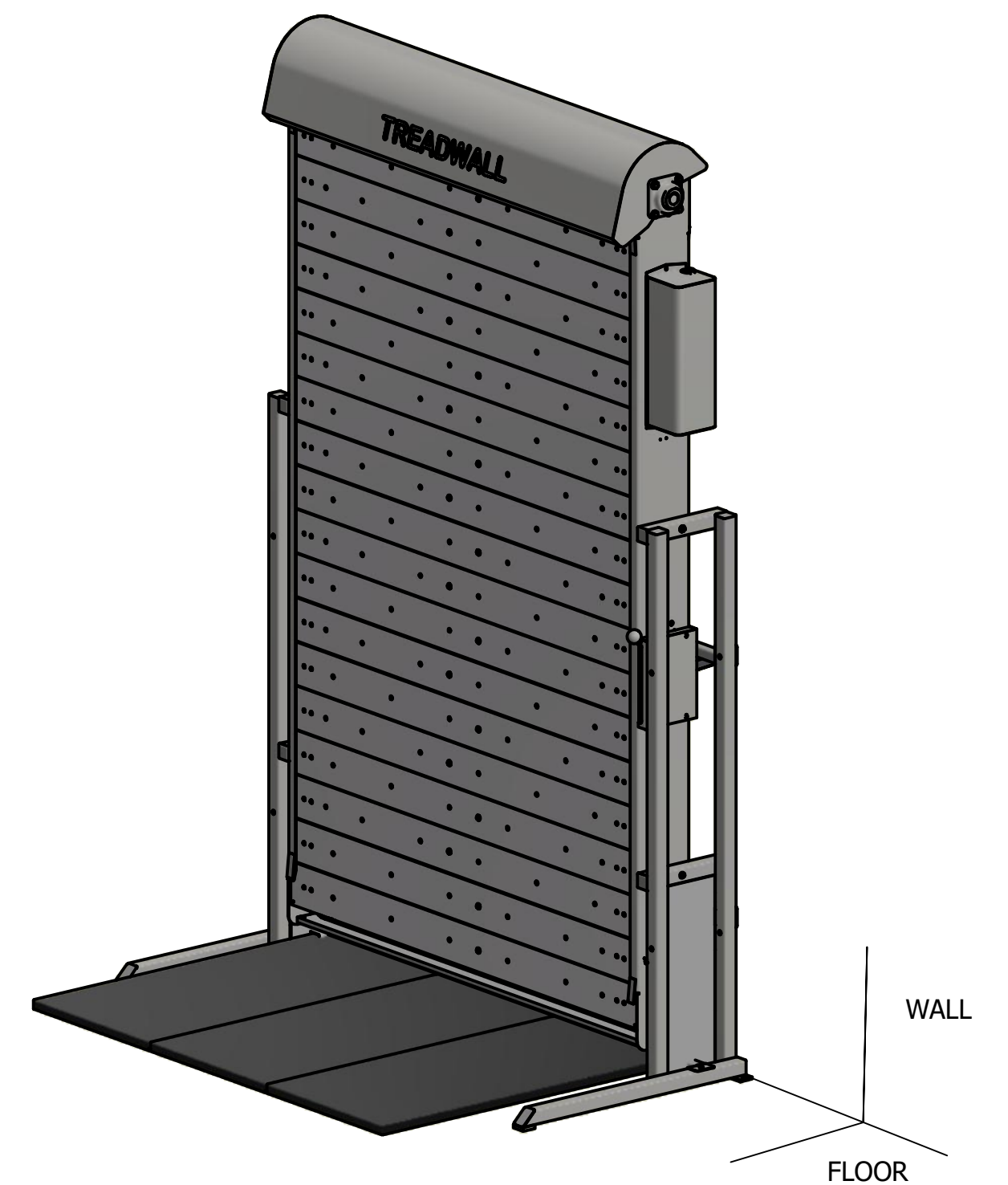

SPECIFICATIONS:

Weight: 419.95 kg.

Construction: Steel framework with custom-machined wood panels.

Placement: Inside standard - outside with exterior upgrade.

Width of climbing surface: 1.524 m.

Total length of climbing surface: 5.08 m.

Number of possible hold placements: 240.

Angle range: vertical only.

Mode of control: Electro-hydraulic braking and resistance.

Electrical requirements: 9 VDC (1500ma) Plug-in transformer (supplied) or battery used.

Electronic Display: Measures distance (feet or meters), time and calories.

Time and distance goals can be pre-set.

Color - frame: Anthracite Gray is standard. Custom colors available.

Color - panels: Natural Wood

Holds: Set of 45 custom training holds in 3 color groups, with optional 14 ladder Line^(tm) holds.

Maximum hold size: 6.35 cm high by 15.24 cm wide.

Floor Mat: 1.016 m x 1.524 m, 3.175 cm dual foam, black 14 oz. vinyl cover.

Warranty: Six years parts, one year electronics and labor.

See full warranty for details.