



Treadwall M6 Pro Owner's Manual



87 York Ave. Randolph MA 02368 | 781-961-5200 | www.brewerfitness.com

TREADWALL M6 Pro

Complete Owners Manual

Table of Contents	
Introduction / Registration	1
Safety tips / Specifications	3
Operating Instructions/hold setup	5
Making Your Treadwall a Success	11
Information for Your Staff	13
Training Tips/Guidelines	14
Activities & Promotional Ideas	16
Frequently Asked Questions	18
General Maintenance	20
Troubleshooting	22
Service Instructions	23
Assembly instructions	28
A-Frame Assembly	29
Main Channel Assembly	33
Glossary	49
Warranty	50
Contact Info	52

INTRODUCTION

Vertical movement is a new category of training that works the whole body and mind together.

The Treadwall delivers a full range of workout opportunities - from a remarkable aerobic burn to an upper-body core and grip-strength workout that challenges the fittest athletes.

When introducing the wall, it is important that the staff understands how to unlock the potential benefits of this powerful fitness tool.

The owner's manual is designed to help managers, staff and trainers take full advantage of this equipment. This reference tool emphasizes the benefits of vertical movement with links and resources to help integrate the wall into fitness routines. In addition, there are incentive programs to help ramp up popularity and much more.

PRODUCT REGISTRATION

Record your serial number here: _____

Please visit brewerfitness.com/OwnersManual to register your new Treadwall with us.

You can also email us at sales@brewerfitness.com with your contact information and serial number to complete your product registration.

You must make sure to register your new Treadwall to receive service updates.

Safety Tips

WARNING - Read all instructions before assembling and using the Treadwall.

For Assembly:

Be careful when moving and installing larger Treadwall components, as they might require effort to lift and attach. Some steps require two individuals. Have a second person assist you during assembly and make sure to have two ladders on hand. Several of the heaviest components need to be lifted to the top of the machine.

For General Use:

Carefully read and understand the Treadwall Owner's Manual. Provide a general overview of the basic operations and usage to new Treadwall users. Do not place other equipment or any items in the fall zone or onto the floor mat of the Treadwall.

M6 Pro Specifications

Weight	1250 Pounds
Dimensions	94" wide x 110" deep x 130" tall
Width of climbing surface	6 feet
Length of climbing surface	20 feet
Number of hold Placements	280
Angle Range	Positive 14 degrees to negative 14 degrees
Electrical Requirements	9 V DC Plug-in Transformer
Electronic Display	Measures Distance in feet, time, and calories
Included Holds	40 custom training holds and 14 Ladder Line
Maximum Hold Size	2.5 inches high x 6 inches wide
Floor Mat	8' x 6' custom mat, 1.25" dual foam
Warranty	10 years on structural parts

Operating Instructions

INTRODUCTION

There are 3 primary controls to know about on the Treadwall M6.

You can adjust the **speed** of the climb with the lever located on the right side of the machine, you can adjust the **angle** of the wall with the wheel placed on either the right—or the left— side of the machine, and you can view and track the stats on your exercise with the **digital counter** on the right side of the machine.

HOW THE TREADWALL WORKS

It's very simple, you can just hop on and climb! The weight of your body will move the wall downwards. With our auto-stop technology, if you stop climbing, the Treadwall will stop and wait for you. The Treadwall will not move unless you are on the wall and climbing upwards.

You can adjust the angle of the wall as well, which makes it easily adaptable to a large variety of abilities and fitness goals. Easier angles are great for aerobic workouts and focus on the lower body. Overhanging angles target upper body strength and really engage the core.

Use the digital counter to set goals, manage your progress, and track your exercises. The counter will begin automatically counting upwards when you start climbing, or you can set time and distance goals on the setup screen.

Control Mechanisms

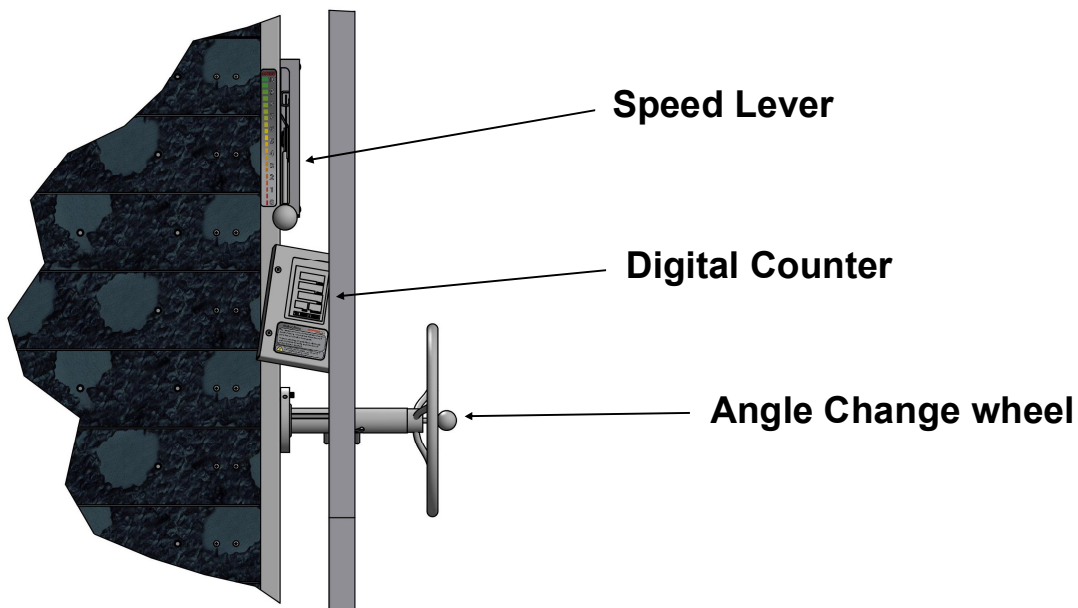

Operating Instructions

Speed Control

To control the speed of your climb you simply move the lever up and down. At the "0" setting the Treadwall will be completely stopped for most people or it may just barely creep downwards for heavier individuals. At speed "10" the wall is at its fastest and only requires about 50 pounds of weight to move. The ideal setting will be different for people of different weights.

Accurate current and average speeds are displayed on the counter in feet/min. or meters/min as required.

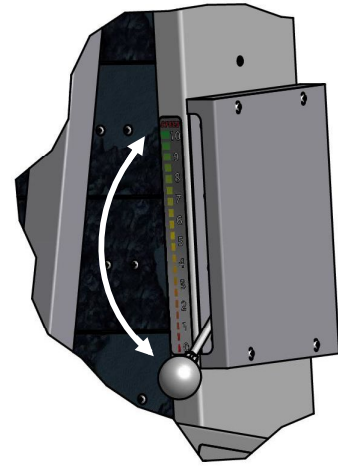

Move wheel slightly to disengage stud

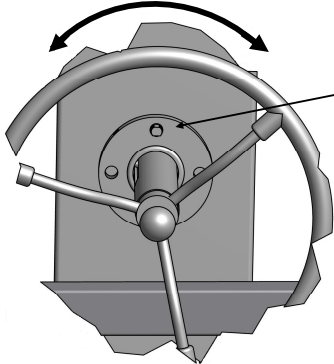

Channel stud inside of locking ring

Locking Ring disengaged and ready to change angle

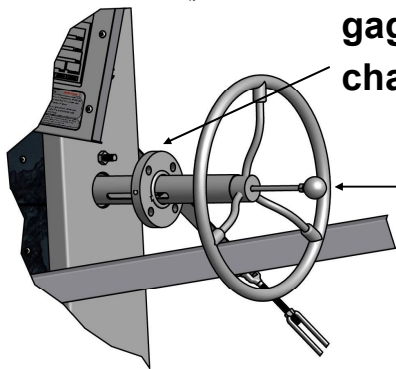

Pull knob outwards to unlock wheel

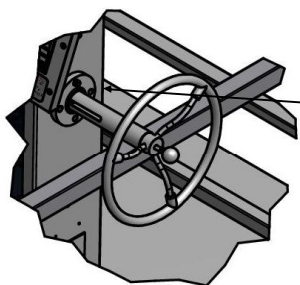

Locked and ready to climb

Angle Changing

Depending on your Treadwall installation the wheel that you use to change the angle can be on either the right or left side on the machine.

To change the angle you first need to disengage the locking ring. To do this rotate the wheel slightly to the left or right depending on the angle of the wall and simultaneously pull gently outwards on the black knob at the center of the wheel.

Once the locking ring is free of the stud on the channel you can turn the wheel, moving the center section to any desired angle. Then, just push the black knob inwards, lining up a hole on the locking ring with the channel stud.

Operating Instructions

Digital Counter

The counter will start as soon as you begin climbing. It will pause if you rest for 5 seconds, and it will power down after 5 minutes of non-use. To turn the counter back on just start climbing, or tap the screen.

You can adjust the view angle by adjusting the small arm at the rear of the counter.

Adjustment knobs

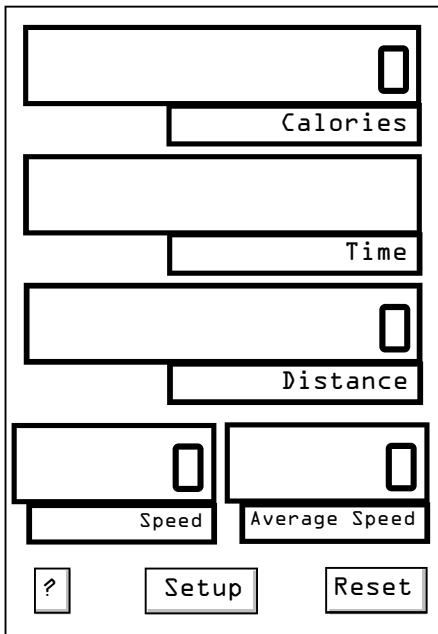
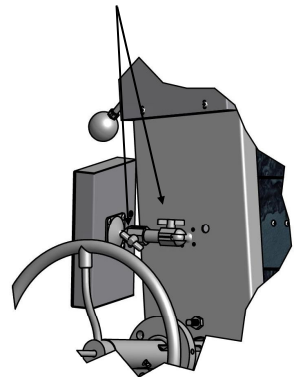

Home Screen

The home screen shows real-time data for a single climb. When you pause for 5 seconds the counter will hold your data on the screen until you begin climbing again and then it will start from where you left off. To reset the counter for a new climber hit

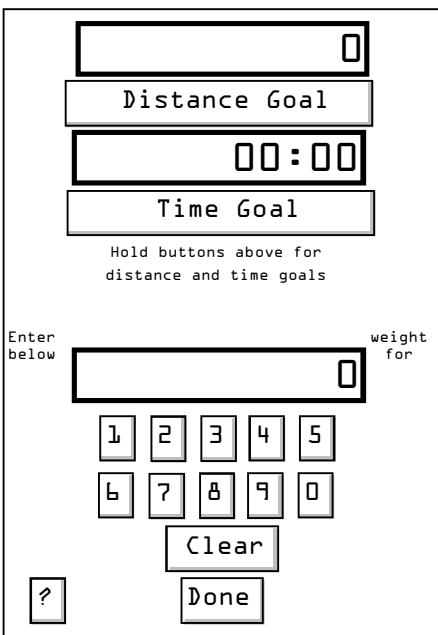

Setup Screen

To set a distance or time goal tap or hold the buttons labeled “Distance Goal” or “Time Goal”. The values will increase more rapidly as you hold the buttons down longer.

The number pad allows you to enter your weight for a more accurate calorie count. The default weight is 150 pounds. When you are satisfied with your goal, hit done and the value you selected will appear on the home screen.

You can only select a distance or a time goal, not both at once.

Operating Instructions

Installing the Ladder Line

The Ladder Line rungs can be installed anywhere you wish on your Treadwall, but we recommend starting with an even spacing of the rungs with little or no deviation from side to side. This provides the best platform for simple aerobic training and fast sprinting climbs.

The Ladder Line is an excellent way to introduce the Treadwall to those who have not climbed in the past or feel nervous about the Treadwall.

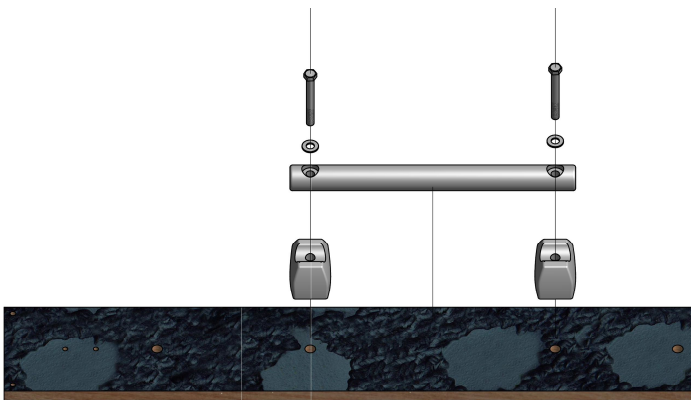

Ladder Line Assembly



Ladder Line Staggered Pattern

Operating Instructions

Installing the climbing holds—Route Setting!

Placing the climbing holds onto your Treadwall is called route setting, and the individual climbs you set up are called routes. On our website at brewerfitness.com/routesetting, you can download, adapt, and even create routes to use and share with others.

The standard set of Treadwall climbing holds comes with 40 holds. There are 13 easy green holds, 14 orange medium difficulty holds, and 13 red holds for the advanced user. You can set individual routes by only using hold of a given color, or you can set up the entire wall and label individual routes with colored pieces of tape.

If you want to try your own hand at route setting one of the most fun ways to start is to place holds almost randomly with one hold per panel. Alternate the color of the holds as you move from panel to panel. Then, try climbing a single color. If you find any move too difficult just move a nearby hold of that color to make the climb feel as hard or as easy as you like.



Assemble holds with a 3/8 bolt and a 5/16" Allen wrench

Climbing Hold Rules

There are 2 important rules to remember when purchasing and attaching holds for your Treadwall.

1. *Holds can not be more than 2.5" tall, this is the projection from the climbing surface.*
2. *Holds can not overlap two panels, the panels must be free to come apart and together as they rotate around the Treadwall.*

Making Your Treadwall a Success

Groundwork:

Staff should understand that vertical movement is a basic human activity, non-contrived and part of everyday life. It should be presented as a positive and accessible addition to the facility.

Climbing will often be perceived as challenging and intimidating activity. A staff locked into the value of vertical movement as a fitness tool is the key for changing this perception. Members should be actively encouraged to try the Treadwall and consider it for part of their workout routine. We have found that people who are initially hesitant often end up being the biggest Treadwall fans.

Choosing an Advocate/Integration

When the Treadwall is first installed, it will be an unfamiliar item. Climbing will be a relatively new training activity for most. We recommend that a staff person be chosen as the main advocate for the product's introduction period. This person might take on the following responsibilities:

1. Read through the manual thoroughly to become familiarized with the Treadwall operation procedures, use and set-up.
2. Formulate a plan to integrate this equipment into their classes, personal training or general usage.
3. Create fun ways to get you members hooked on Vertical Movement - challenges, competitions and incentives (such as our popular Everest Club program).

Set up a meeting with trainers to Establish Goals and Discuss Ideas:

1. Cross-training for sports that emphasize forearm strength such as martial arts, baseball, swimming and tennis.
2. Weight-loss programs. Focus on manageable goals, using easier positive angles. Emphasize smoothness over speed.
3. For Cardiovascular try 15 minutes once a week or every two weeks in place of a treadmill.
4. As a warm-up, especially for lifting. Suggest using ground-based training (hands only) for larger lifters.

Information for Your Staff

The Benefits of Vertical Movement: *Valuable Information*

Most fitness activities target isolated muscle groups, but vertical movement is different. Using a Treadwall provides a full-body, non-repetitive exercise that can be adapted by the user for different goals. You can customize the experience by adjusting the exercise patterns, angle of the wall and climbing speed.

In terms of focus and mental involvement, climbing has no peer. The activity requires constant decision-making and concentration. This promotes a quick motor response and muscle recruitment. Technique, balance and core strength interplay and climbers often develop a heightened sense of body awareness and confidence in their daily lives.

The Treadwall is very versatile. It can stand alone as a high-energy interval trainer, with longer workouts to develop endurance, or as part of a circuit routine with other equipment.

Customize it to suit YOUR needs and GOALS:

- 1) You should use the equipment yourself. Get a first-hand look at how the workout makes you feel, learning to access angle and speed to accommodate a range of abilities. Experience the benefits of vertical movement personally.
- 2) At first, clients might consider this equipment to be intimidating, but knowledge you can pass on to your members about training and benefits will help bridge the gap.
- 3) Check out all the different ways it can be used, experimenting with different hand grips, angles, speeds and body movement. Your personal experience and enthusiasm will engage the user. Be creative.

Encourage Members to Try It Out:

Introduce it at the easier positive angle first so that members can get familiar with the balance and motions involved. The workout on the Quick Start guide at www.brewersledge.com/ownersmanual is a good place to begin.

Emphasize controlled, smooth climbing and attention to balance and footwork.

Suggest short workouts to start, which will complement their current workout routine.

Training Tips/Guidelines

Below you will find different training tips we have learned over the years that can ease your clients into Vertical Movement.

Initial Exposure When your clients and members are trying out the Treadwall for the first time:

1. Ensure speed is on zero before having them climb.
2. Ask if they would like you to control speed at first.
3. Encourage them to try adjusting the speed themselves: Set the speed to 0 and tell them to climb about half way up. Let them know that at settings 7 to 10 the speed is quite fast, so move the speed lever slowly. All they have to do is hang on, reach for the speed lever, and pull it up a small amount.
4. Have them take it slow at first and focus on smooth movement.
5. Emphasize the need to move your feet above a certain panel to keep the wall moving. Auto-stop will automatically stop the rotation as they approach the bottom.
6. Tell them they can keep going even after the auto-stop has engaged, just continue climbing and the wall will resume rotation.

Initial Workout:

Most people are unfamiliar with climbing holds, and the Ladder Line is an excellent way to introduce them to the basic balance and movements. Try having them start on the Ladder Line first for a couple of minutes to get a feeling for it.

As they continue to climb, then suggest using a few of the climbing holds as well as the Ladder rungs.

If the client is looking for a more complete challenging program, or you need ideas, refer to our website where you will find complete training programs and sample workouts.

www.brewerfitness.com/info/training

Training Tips/Guidelines

Climbing is a progressive activity—there is a great deal to learn about balance and technique. The initial workouts should emphasize the fun and excitement of re-learning an activity that has roots in the earliest childhood years. As climbers progress and become more comfortable, they naturally and inevitably gravitate to the more challenging aspects of the sport.

Climbers love “problems” - climbing problems that is. They seek them out. They talk about them. They work on them—sometimes for months or even years. Few things in life are more satisfying than solving a tricky, elusive “problem” that initially seemed completely improbable if not downright impossible.

QUICK HINTS:

1. Start them **slow**. Remind about auto-stop sensor panel.
2. Focus on **Safety**. Don't jump off—ride it down. It will stop at the right height to step off .
3. Tell them they are **not very high** off the ground if they seem reluctant (focus on the padding below).
4. Mention the **benefits** of **Vertical Movement** so they are aware of **WHY** they should use the equipment.

Full-Body/Burn Calories/Lean Muscle/Core Strength/Balance

1. Refer www.brewerfitness.com/ownersmanual for downloadable versions of the **Quick Start** guide, printable Training Logs, resources for articles on the benefits of climbing etc.
2. Refer to our website for **full training program** ideas and short workouts.

Activities & Promotional Ideas

Setup a Mt. Everest club challenge for staff and members:

Perhaps use teams. (Brewer Fitness provides free Everest Club membership to the first three staff members to complete the challenge.

Recognize the first members to start on Mt. Everest Club challenge:

Use the bulletin board to put up names and perhaps pictures.

The Everest Club:

Climb 29,028 feet on the Treadwall and you are eligible to join. You can find the Everest application and a training log at www.brewerfitness.com/OwnersManual

Special incentive:

Brewer Fitness provides free Everest Club Membership to the first three staff members to complete the Everest Challenge

Completing the Everest Challenge is a major accomplishment. Climbing 1000 feet a day, seven days a week, it will take a full month. For most people it will take the better part of a year. Anybody who completes this challenge will come out a different person—fitter, stronger, healthier, and most likely more confident. An important advantage to having a Treadwall is being able to offer this unique program.

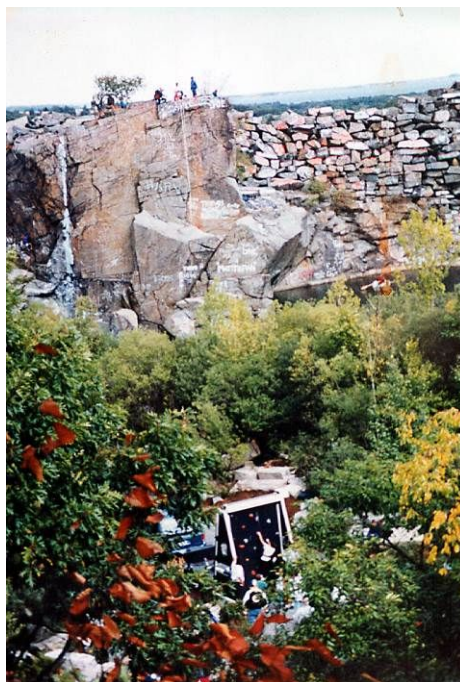

Activities & Promotional Ideas

Elevation/Location

- 30' Typical street lamp
- 40' Height of the Parthenon
- 190' Niagara Falls (American Side)
- 302' Statue of Liberty
- 555' Washington Monument
- 607' Space Needle, Seattle
- 642' Top Span, Astrodome roof.
- 984' Eiffel Tower, Paris
- 1250' Empire State Building, New York
- 1454' Sears Tower, Chicago
- 2,717' Burj Khalifa (tower in Dubai)
- 3200' Angel Falls, Venezuela
- 4610' Mt. Vesuvius, Italy
- 5117' Devil's Tower, Wyoming
- 5267' Mt. Katahdin, Maine
- 6288' Mt. Washington, New Hampshire
- 7310' Mt. Kosciuszko. high point in Australia
- 7569' El Capitan, Yosemite National Park
- 8842' Half Dome, Yosemite National Park
- 9570' Mt. Olympus, Greece
- 11245' Mt. Hood, Oregon
- 13766' Grand Teton, Wyoming
- 14161' Mt. Shasta, California
- 14495' Mt. Whitney, high point continental US
- 14692' The Matterhorn, Germany



Other Ideas:

1. Other distances : trail length (Appalachian), Body of Water Length (English Channel)
2. Weekly "Tread crew," meet up group
3. Bi-monthly Competitions using wall (Triathlon: Rower, Pool, Tread-wall) or other cardio pieces

Frequently Asked Questions

Q&A

How hard is climbing on the Treadwall?

Climbing on the Treadwall is as hard or as easy as you choose. The wall is customizable in difficulty by altering the speed, angle and route you follow.

How fast can I climb on the Treadwall?

The Treadwall is easily adjusted via the speed lever. In addition, the auto-stop system will keep pace with your stops and starts. We recommend starting off climbing at a slower controlled pace, focusing on smooth movement.

How does the Treadwall work?

The Treadwall operates by the weight of the climber. There are no electric motors. A hydraulic brake controls the speed of descent. The Treadwall cannot move after the climber steps off.

How long should I climb for?

This depends on your objectives. Test out various methods and take a look at our training section: www.brewerfitness.com/index.php/info/training

Will the hold pattern get repetitious?

Eventually, but it takes much longer that you might expect. The Treadwall has no beginning or end, and it continually presents you with new challenges and possibilities. It is simple to set holds in other places and change the climb completely.

Do I need special shoes to climb the Treadwall?

No. Any well fitted athletic shoe will do quite well. However, special climbing shoes are more enjoyable to climb in. Climbing shoes are very close fitting with a special flat sole of special 'sticky' rubber. They are quite expensive. Karate shoes are a good inexpensive alternative.

Can anybody use the Treadwall?

Almost anyone can perform vertical movement. Anyone with a serious physical problem should consult with their doctor, and people with very long fingernails should think twice. We also suggest taking off your rings before climbing.

Can you be too old to climb?

Maybe, but we have reports of people well into their 70s who enjoy climbing on the Treadwall. One climber 72 years old recently completed the Everest challenge (29,028 ft.) - for the second time!

Frequently Asked Questions

Does everyone like it?

Most people who try the Treadwall love it. Some of the biggest fans are people who start off saying "I don't think I'd like that." Everyone should be encouraged to give it a try.

I have never done that. Will it take me long to learn?

Never climbed? - not likely. Most children spend many happy hours climbing play equipment and trees. For adults, climbing on the Treadwall recaptures much of that simple joy and natural vertical movement.

What kind of bodies does Vertical Movement build?

Climbing and gymnastics are similar, promoting muscle tone, flexibility and endurance with increased agility and body awareness. Your body will respond by burning fat, creating a lean muscle structure and increasing bone density

Do serious climbers like the Treadwall? Yes, it is a perfect endurance training tool, all the way from elite climbers to a novice.

General Maintenance

INTRODUCTION

Treadwall® maintenance is easy and requires only lubrication and cleaning. The most important maintenance of the Treadwall occurs during the first month of operation when the chain and cables are stretching to their final length. It is very important to keep the angle-adjuster cables tight during this break-in period so that the coils remain even and do not overlap. Also the drive chain must be tightened after 2-3 weeks of use. Instructions for these adjustments are included here.

THEORY OF OPERATION

The Treadwall M6 Pro is completely powered by the climber. The wall does not rotate by itself, but only when a person begins to climb on the machine. You can vary the speed of climbing with the lever located on the right side of the machine. This lever controls a hydraulic resistance unit located at the top of the right channel. The hydraulic resistance mechanism is connected to the main shaft with a short chain.

The M6 Pro also contains our auto-stop system which is triggered when the weight of the climber reaches the bottom of the machine. The Treadwall will not move when someone is standing and not climbing upwards. The sensor for this system is located at the bottom right side of the machine. There is a small switch which closes an electric valve in the hydraulic system.

The panels slide through the side channels on small plastic buttons which help reduce friction in the system.. These buttons are located on the top front face and the bottom rear corner of each panel. Buttons only need to be located in these 4 locations since the panels twist when weighted by a person. The panels also contain 7 welded fasteners which allow the climbing holds and various attachments to be added in any configuration the user wishes.

The entire center section of the wall pivots from the top of the A frame to allow for the angle of the machine to change. This is controlled by synchronized wire cables on either side of the Treadwall. The cables are wrapped around a tube which has a movable collar that allows the tube to be locked into place by pushing on, or pulling, a knob in the center of the adjuster wheel.

There is also an electronic counter on the right side of the machine that allows users to track distance, time, and calories. The sensor for this system is located on the inside top of the right channel. The sensor detects a series of three magnets placed on the main top shaft.

General Maintenance

Maintenance Schedule

After The First Month:

- Check the drive chain to make sure that it is not loose. Tighten if necessary. (Pg. 17).
- Check the coils on the angle adjuster cables. Tighten the slack that will develop. (Pg. 30).
- Check and tighten holds if necessary. They may loosen more readily as the panels adjust to your gym.

Every 6 Months:

- Lubricate the side channels (Pg. 19) —*This can be done more or less frequently depending on usage.*
- Clean the Climbing holds and set new routes. (Pg. 19)
- Wipe down and clean machine.

How to access the inside of your Treadwall

The Treadwall wall panels are bolted to a set of chains. These two chains form a continuous loop around the top and bottom axles. Each panel is attached to flanges mounted on the chains with 4 Philips head bolts and 3/8" lock nuts.

Rotate the wall so that the desired panel is lined up with the access hole. Remove the cover, then remove panel bolts and nuts. Rotate the wall downward and allow the panel to drop out at bottom. Multiple panels can be removed in a similar manner if necessary. Rotate the wall until the opening is at the height where service is required. Reverse this process to reattach the panel and cover up the access hole.

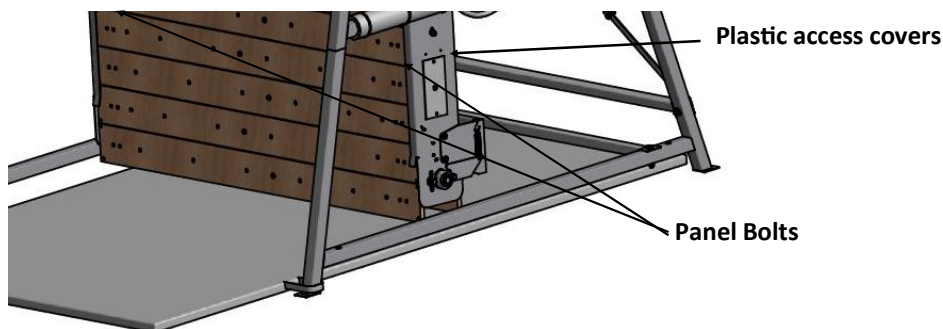

Troubleshooting

Problem	Cause	Solution
Entire Treadwall wobbles or moves	Exterior X-bracing too loose	Tighten the exterior X-bracing making sure that the entire frame is square and level (Pg. 16)
Main channel section sways side-to-side	Internal x-bracing too loose.	Tighten Internal x-bracing. Do not over-tighten. Tighten until just firm. When you have completed this adjustment, make sure locknuts on the turnbuckles are very tight (Pg. 16)
Chain makes slapping noise	Drive chain too loose	Tighten drive chain and make sure that lock nut is tightened firmly (Pg. 17)
Speed control lever does not work	control cables may need adjusting	Remove hydraulic cover and inspect the path and tightness of the control cable. (Pg. 17)
Auto stop doesn't work or works erratically	Microswitch needs adjustment	Check and adjust the small switch at the bottom of the right channel. Also, make sure that unit is plugged in and receiving adequate power . (Pg. 18)
Wall is sluggish: lighter weights will not pull wall down	Either the drive chain too tight, the channels need lubrication, or the ends of the panels are rubbing the channels	Loosen the drive chain (Pg. 17), lubricate the Treadwall (Pg. 19), and check the internal x-bracing (Pg. 16)
Hold rotates	Hold bolts not sufficiently tightened	Re-check hold bolts; re-tighten with a 5/16" Allen Wrench
Display does not power on	The Treadwall is not plugged in, not receiving adequate power, there is a loose connector, or a wire is cut	Check that the Treadwall is plugged in and the power outlet is working. Check all connectors and cables for good fit and good condition
Display is powered up but will not start counting	Sensor and magnets not adjusted properly, broken, or missing	Check the sensor located on the inside top of the right channel. The gap should be no more than 1/8" (Pg. 18)

Service Instructions

Frame Alignment

Adjust to these dimensions if the wheel is on the right side (as shown). If the wheel is on the other side, adjust so that there is a bit more room on the wheel side. This will make the angle adjustment easier. The slight angle of misalignment will not affect the operation of the Treadwall.

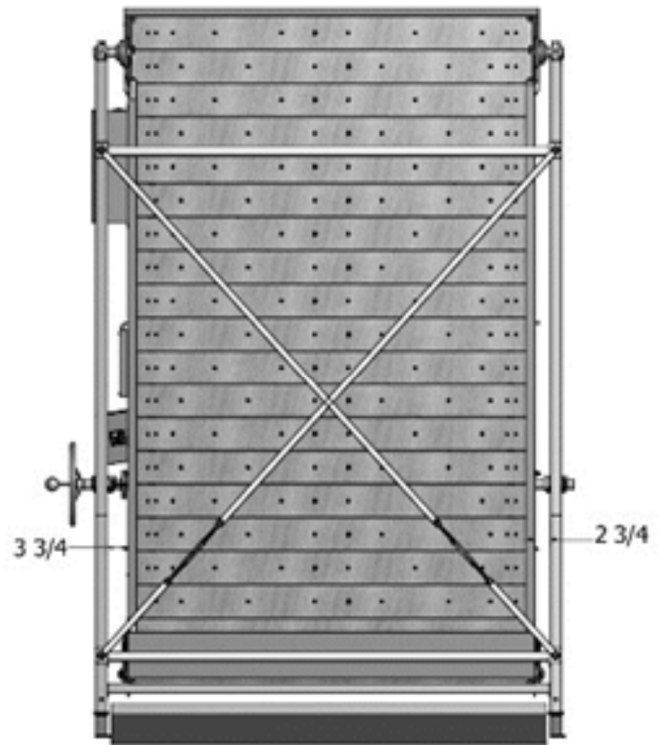

Internal X-bracing adjustment

If the internal X-bracing is too tight the panels may be restricted in their movement. If too loose, the wall can sway from side to side.

For best function the center section of the Treadwall should hang level with both turnbuckles approximately the same length.

TO adjust the x-bracing, remove the plastic covers at the bottom of the channels, loosen the lock nut on the x-bracing, and then adjust until the wall is straight and level and you can not easily move the center section from side to side.

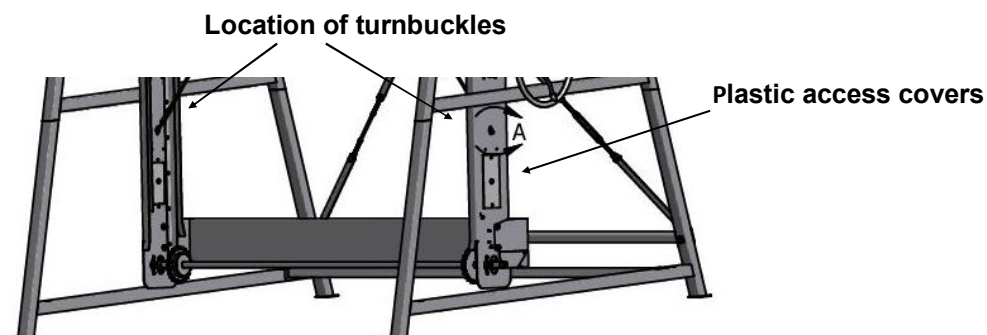

Service Instructions

Drive Chain Adjustment

1. The drive chain can be adjusted from the outside of your Treadwall, you only need to remove the hydraulic box cover on the top right of the machine.
2. Loosen the locknut on the adjustment screw, and tighten the screw down onto the pump. Only make it finger-tight. If the chain is too tight, the Treadwall will operate sluggishly.
3. Tighten the locknut and check the chain – feel it with your finger at the inspection hole. There should be no slack, but not too tight.

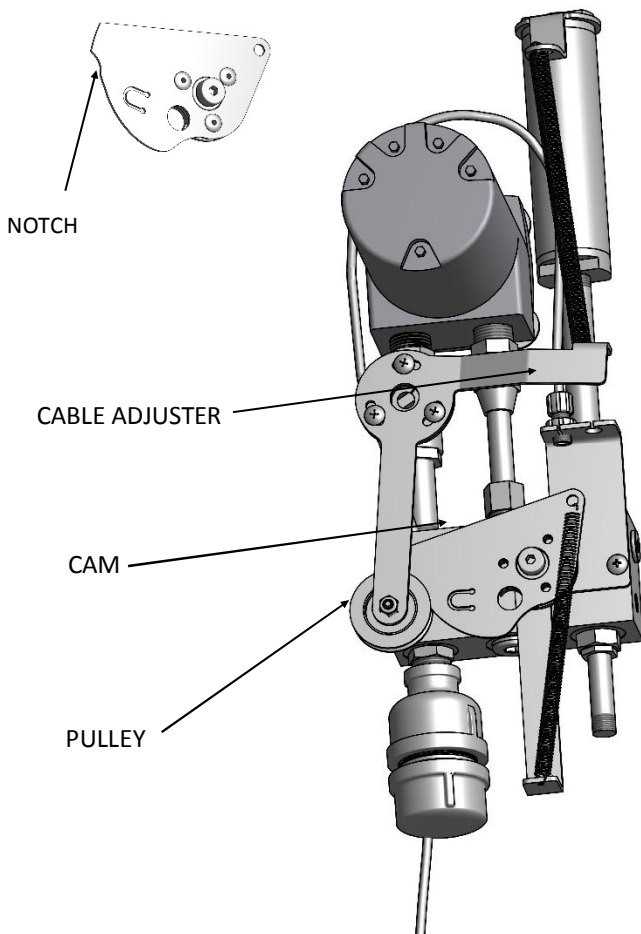
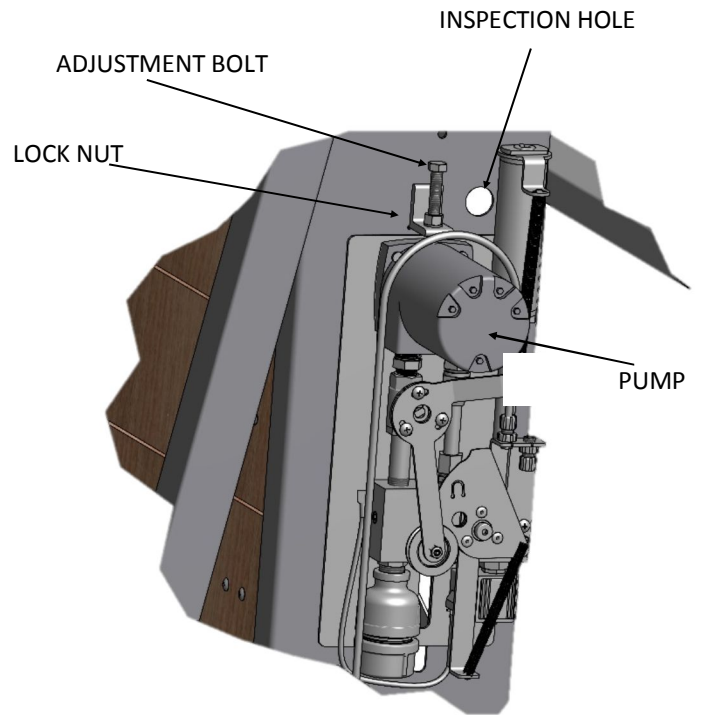

Speed Lever Adjustment

1. Adjust the speed lever to the slowest position.
2. The hydraulic unit is at the top of the right channel. Remove the cover (two screws).
3. Note the cam and pulley that together control the valve. With the lever at slowest position, the pulley should be at the highest point of the cam. There is a notch at the highest point that the pulley fits into.
4. If the pulley is not at the highest position, tighten the cable with the adjuster.
5. Operate the lever a few times to check the adjustment. If the wall still creeps excessively, see the instructions for adjusting the cam follower.

Service Instructions

Auto-Stop Adjustment

1. Loosen the two small nuts on the outside of the channel that hold the microswitch in place.
2. Adjust the microswitch by pivoting it around its upper mounting screw (see diagram).
3. Retighten the small nuts (not too much force – they are very small!)
4. Test the wall and re-adjust if necessary.

If the microswitch needs to be inspected further or replaced remove the plastic access hole cover and all nuts and washers from the microswitch. Reach inside of the access cover and unclip the electrical wire from inside the channel and pull the microswitch out.

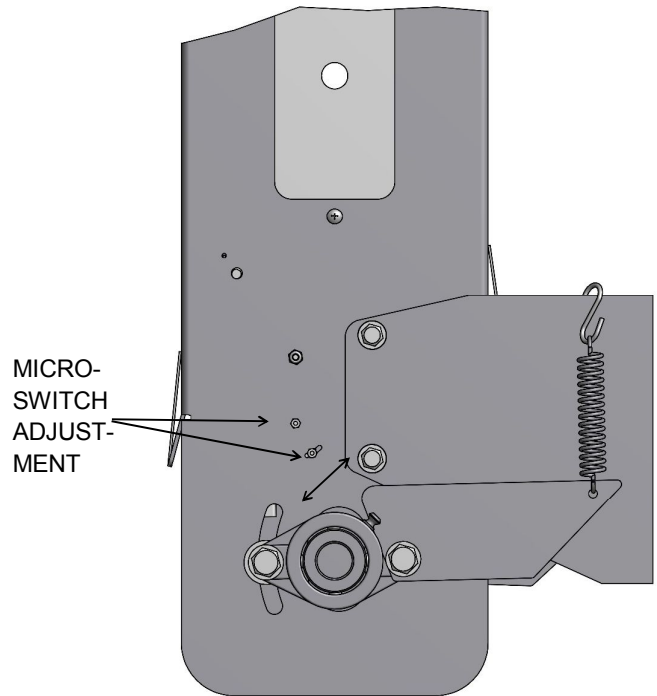

BOTTOM OF RIGHT CHANNEL

Counter Sensor Adjustment

1. Remove 1 or 2 panels
2. Rotate panel gap to reveal sprocket and sensor assembly on right side of machine.
3. Inspect sprocket and make sure that three magnets are present, they should be equally spaced around the shaft with the flat face of the magnet facing outwards
4. Inspect reed switch position, the tip should be 1/8 to 1/4 inch from the magnets.

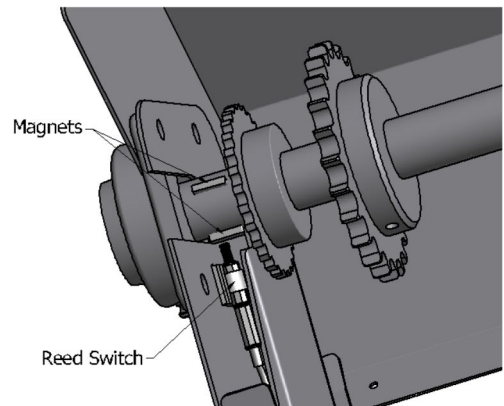
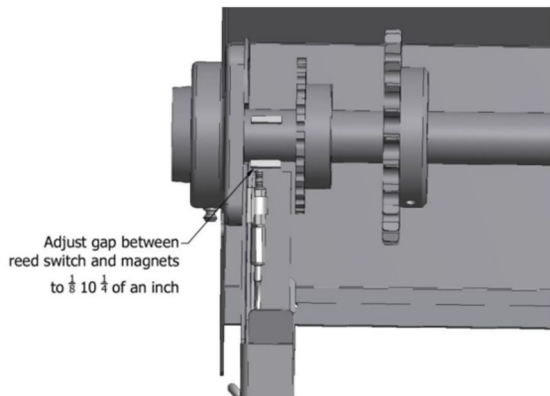

Service Instructions

Lubricating the M6 Pro

The Treadwall panels slide down channels that should be lubricated bi annually, or more often if operation becomes sluggish.

1. White lithium grease in a spray can is commonly available at auto supply and hardware stores. Make sure your purchase includes the thin straw-like extension for the nozzle.
2. There are four channels to be lubricated. Two in the front and two in the back. Each channel has a rear surface and a front surface.
3. To lubricate the rear surfaces (fig 1), put the nozzle into the gap between two panels and squirt a little bit of grease onto the rear channel surface. Do this for all the gaps in the front and rear of the Treadwall (about 70 gaps total).
4. To lubricate the front surfaces (fig 2), put the nozzle in between the panel and the front of the channel and squirt a little grease at the top and bottom corners of the panel. Do this for each panel – front and rear.
5. Don't over-do the greasing. Just little squirt is plenty.

Fig 1

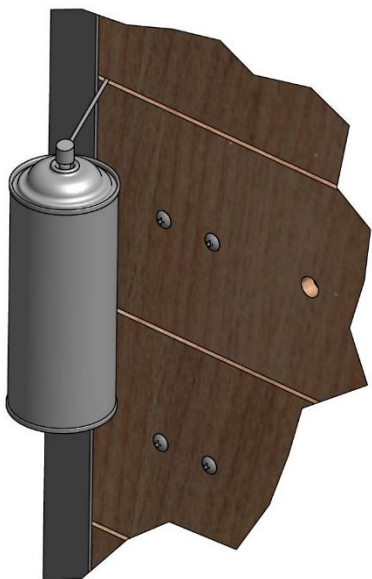
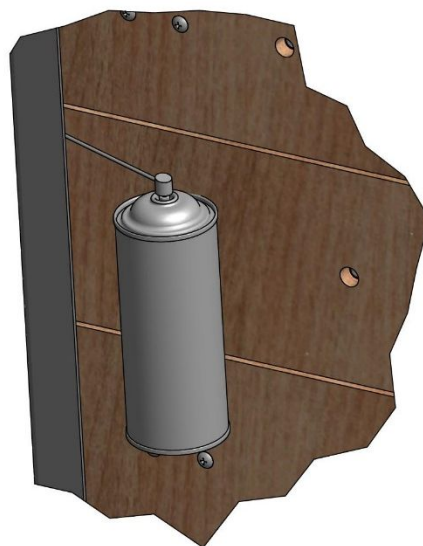

Fig 2



Safety Tips

WARNING - Read all instructions before assembling and using the Treadwall.

For Assembly:

Be careful when moving and installing larger Treadwall components, as they might require effort to lift and attach. Some steps require two individuals. Have a second person assist you during assembly and make sure to have two ladders on hand. Several of the heaviest components need to be lifted to the top of the machine.

For General Use:

Carefully read and understand the Treadwall Owner's Manual. Provide a general overview of the basic operations and usage to new Treadwall users. Do not place other equipment or any items in the fall zone or onto the floor mat of the Treadwall.

M6 Pro Specifications

Weight	1250 Pounds
Dimensions	94" wide x 110" deep x 130" tall
Width of climbing surface	6 feet
Length of climbing surface	20 feet
Number of hold Placements	280
Angle Range	Positive 14 degrees to negative 14 degrees
Electrical Requirements	9 V DC Plug-in Transformer
Electronic Display	Measures Distance in feet, time, and calories
Included Holds	40 custom training holds and 14 Ladder Line holds
Maximum Hold Size	2.5 inches high x 6 inches wide
Floor Mat	8' x 6' custom mat, 1.25" dual foam
Warranty	10 years on structural parts

Assembly Instructions

Before Assembly:

The most important first step is to consider carefully the location and position of your Treadwall. A location that is too visible - for example in the direct focus of members using CV equipment or walking in the entrance - may discourage people from climbing. Often simply rotating the Treadwall slightly will dramatically improve its usage.

The ground should be flat and level and the area directly around the Treadwall should be clear of any hazards for the climber or trainer. The Treadwall fits well in the cardio area of a gym.

Tools required and set up:

In addition to the tool list you will need a helper and two ladders. If you are tight on space begin by assembling the A-frames and then bring in the side channels and shroud and place them directly onto the machine.

Assembly will take 6-8 hours, please read the entire assembly procedure prior to starting the install. If you do have questions please contact us at 1-800-707-9616.

WRENCHES:

- 1 - 9/16 open end wrench
- 1 - ¾ open end wrench
- 1 - small 3/8" sockets for panels
- 1 - 9/16 socket
- 1 - ¾ socket
- 1 - socket wrench
- 1 - Allen set, SAE
- 1 - crescent or universal wrench

SCREWDRIVERS:

- 1 - Set of screwdrivers
- 1 - Cordless drill or screwdriver
- 2 - Phillips driver bits for drill

PLIERS:

- 1 - vice grip
- 1 - needle nose pliers
- 1 - wiring pliers (good for working with master links on chains)

A-Frame Assembly

Parts Needed

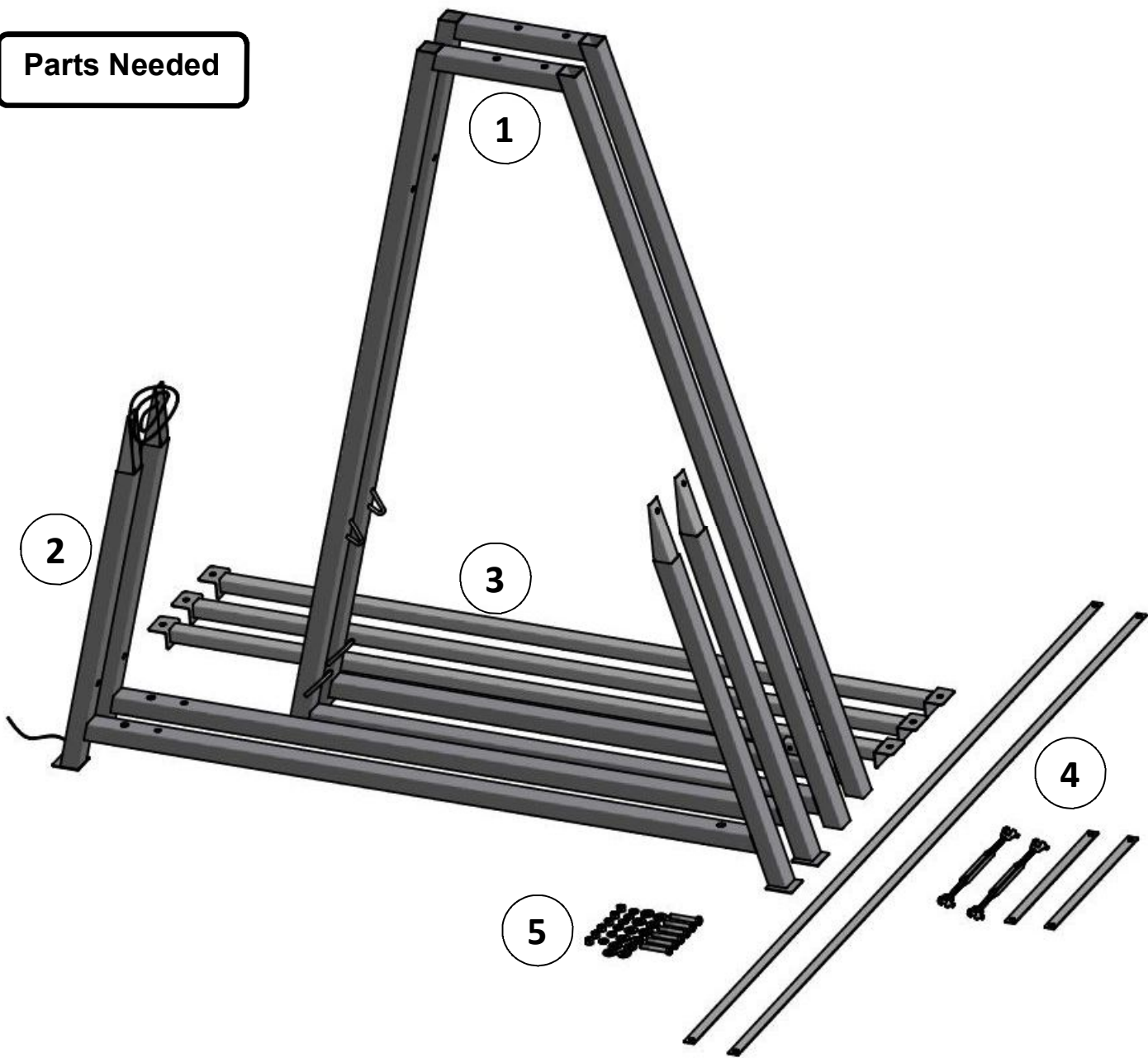

1	Upper frames
2	Lower Frames—The right side has a wire which goes to the rear of the Treadwall
3	Horizontals
4	X-brace components—The two short pieces and two long pieces are packed with the channels, the turnbuckles are in the hardware box.
5	Hardware bag M6-2

A-Frame Assembly

Assemble the lower frame as shown.
Tighten the bolts firmly but not too tight.
Be careful not to distort the metal.

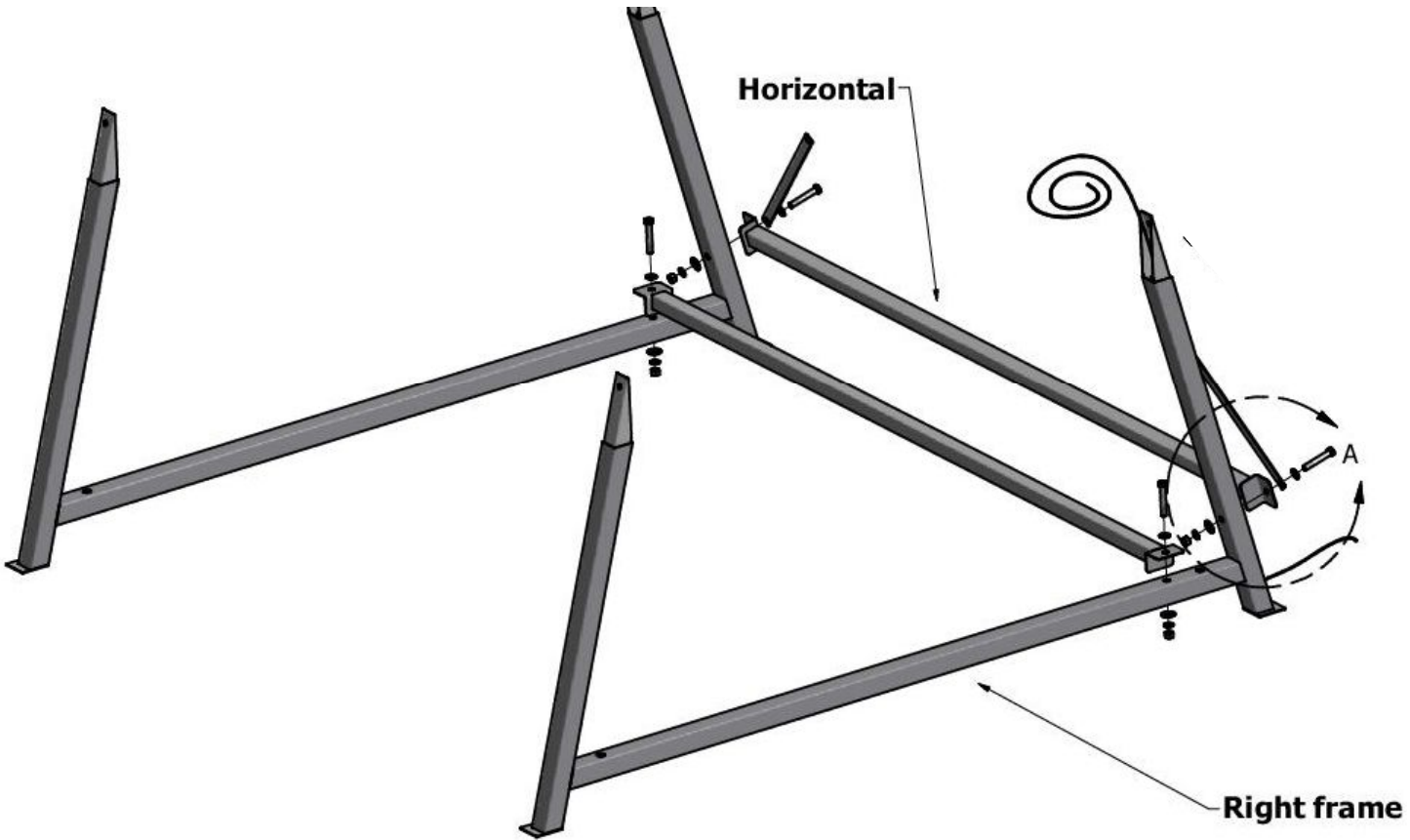
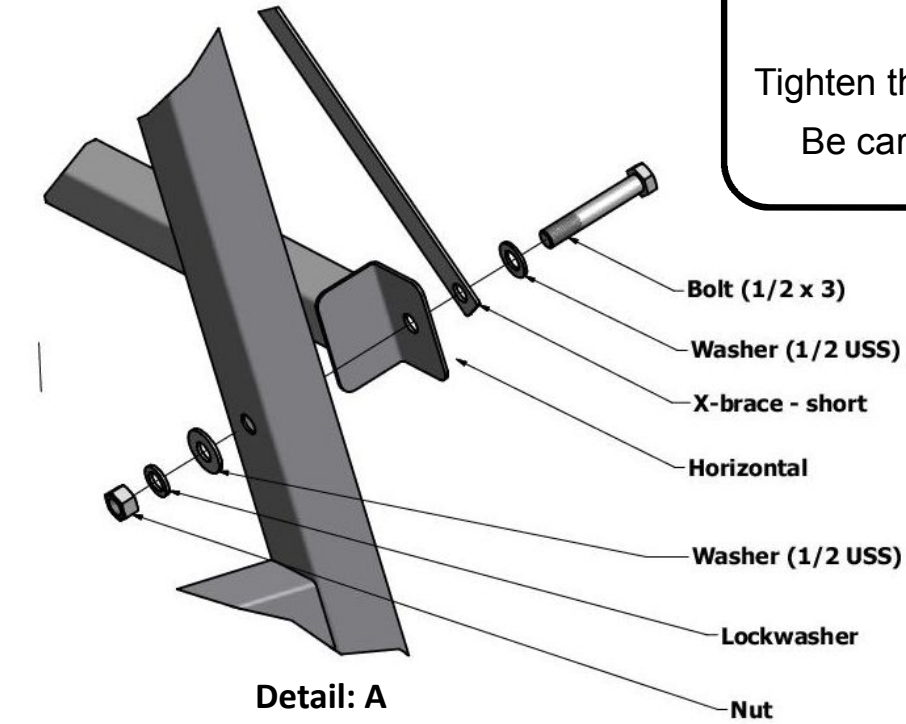

A-Frame Assembly

Assemble the upper frames to the lower frames

Note:

The top frames have holes in the back legs for the upper horizontal. Make sure these holes are at the back when you assemble the frames.

Before assembling the right frame, fish the wire through the rear leg up to the top of the frame. Be careful not to pinch the wire when assembling the frame.

Lift the upper frame and slide the back leg together first as shown. Do not try to put the front leg together until the back leg is completely together.

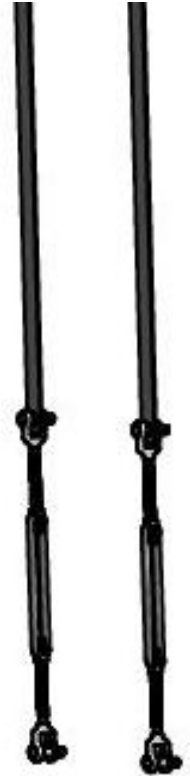

Prepare the long x-braces by attaching a turnbuckle to one end of each.

Turnbuckles are adjusted by holding the two ends and turning the center section.

Before attaching the turnbuckles, turn them out so that they are close to their maximum

A-Frame Assembly

Until the x-braces are connected and tightened, the frame will be quite shaky. Don't stand on any part of the frame until it is completed - use ladders.

Assemble the top horizontal along with the long x-brace assemblies.

Attach the turnbuckles to the short x-braces and tighten them up.

When the turnbuckles are tight, they should be the same length. Check with a tape measure.

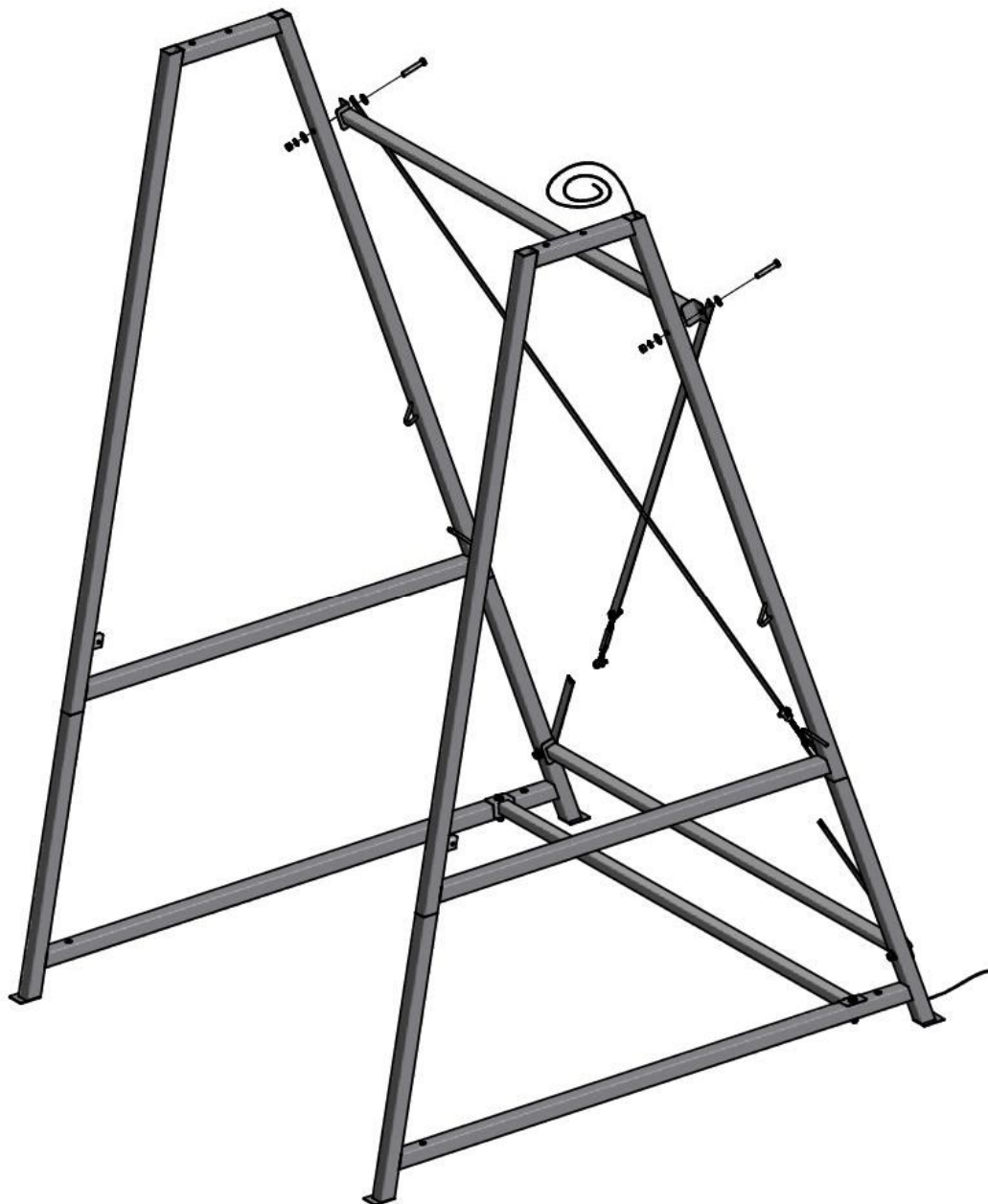

Main Channel Assembly

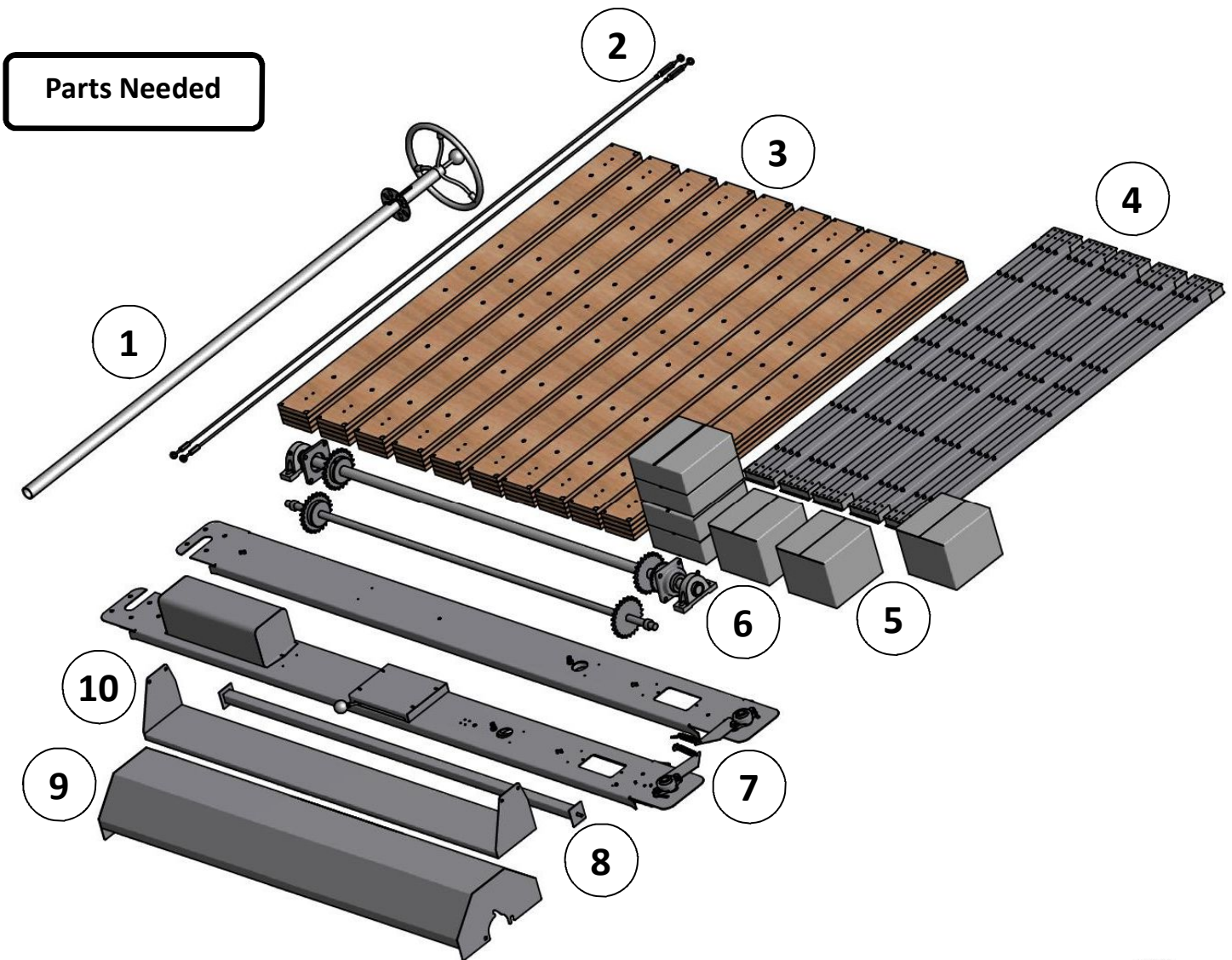

- 1 Angle Adjuster Tube
- 2 Internal X-bracing
- 3 Panels
- 4 Stiffies
- 5 4 chain boxes, hardware box, hold box, and Ladder line box
- 6 Upper and lower shaft—upper shaft has bearings.
- 7 Main channels—Right side has hydraulic speed control
- 8 Spacer bar
- 9 Upper shroud with Treadwall Logo and post pads
- 10 Lower shroud

Main Channel Assembly

The next few steps involve lifting and installing parts at the top of the Treadwall. This is about 9 feet off the ground and some of the parts are quite heavy and awkward. *You should have two 8 foot stepladders and two people for this part of the installation.*

Position your ladders inside the front of the A-frame and lift the main shaft into position. Note that the end with two chain sprockets goes to the right. Install the shaft at the top of the A-frame with four bolts included in bag TW6-

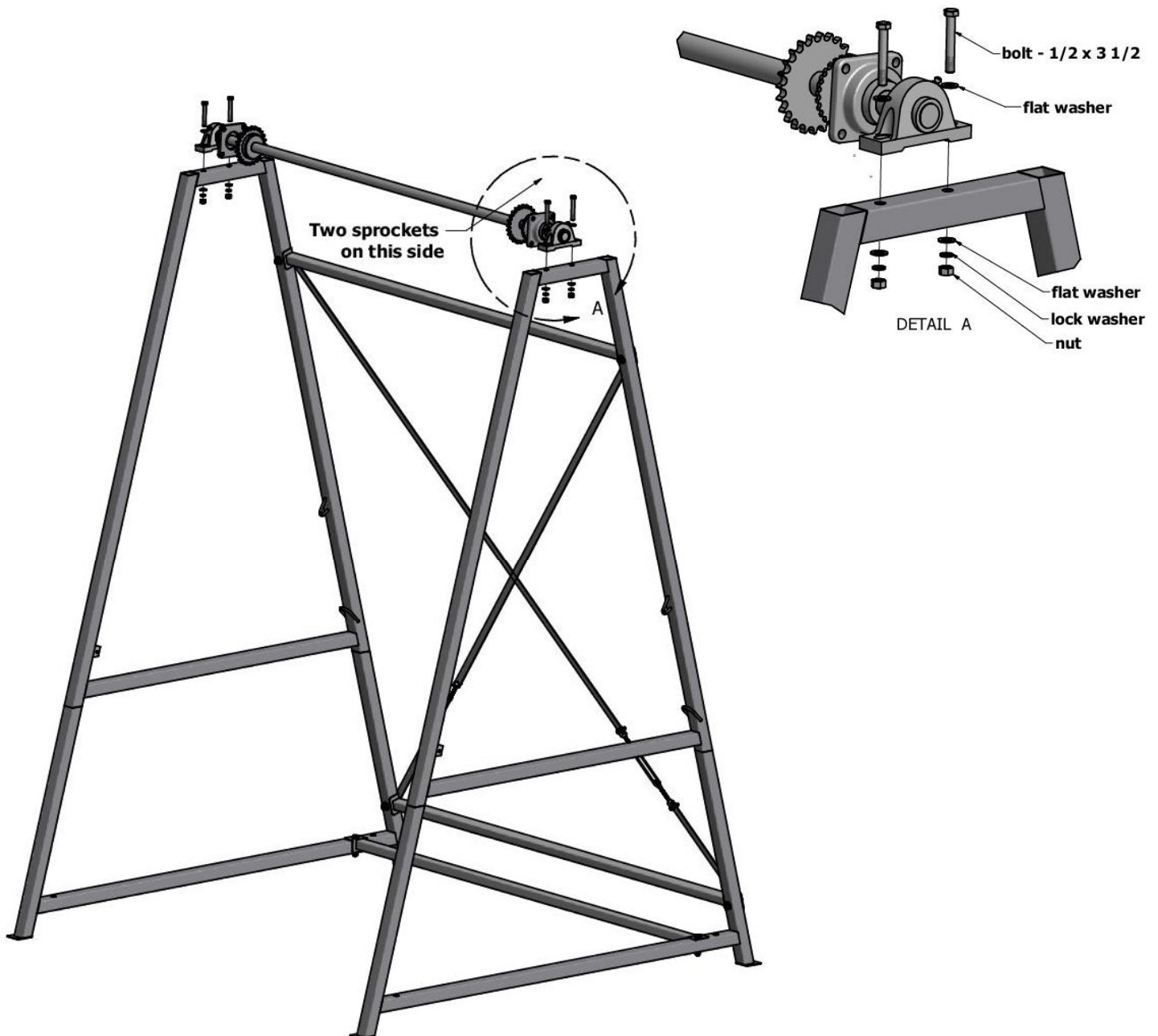

Main Channel Assembly

Install the left and right channels by hooking them onto the main shaft directly behind the square bearings.

This diagram shows the assembly after the left channel has been installed and the right channel is being put into place. The channels - particularly the right channel - are heavy, and require two people.

When the channel is in place, attach it to the square bearing with three flange bolts from bag TW6-6. Leave the nuts very loose so that the shroud can be slipped under the bolt heads in a later step. Lining up the holes between the channel and bearing after the first bolt is in place is much easier if a person on the ground lifts the channel slightly.

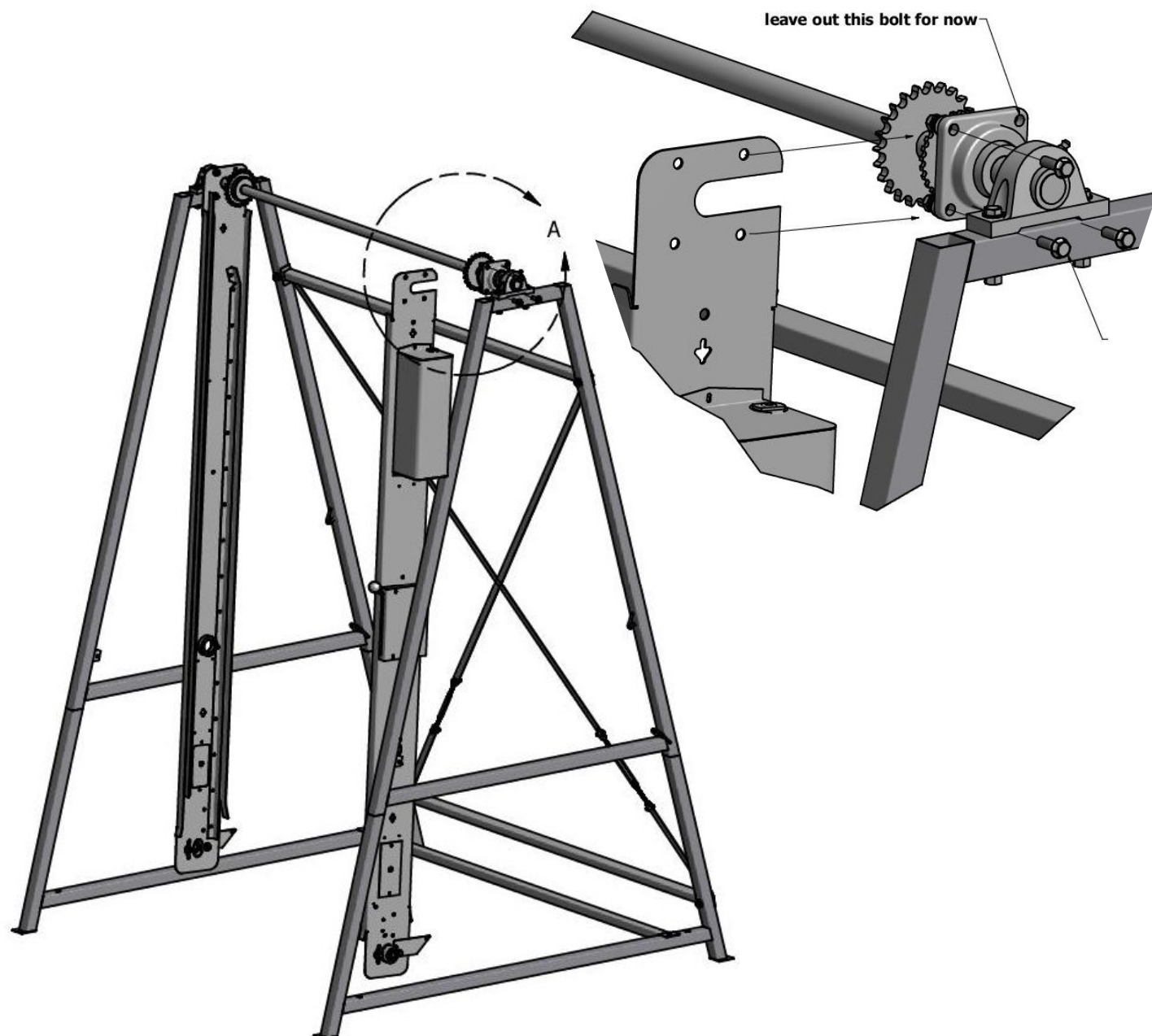

Main Channel Assembly

Install the lower shaft into the bearings at the bottom of the channels. One sprocket on the lower shaft is loose, this should go on the left side of the machine. This does not require a set screw — it will self align.

Check that the setscrews in the channel bearings are turned out so that they will not interfere with insertion of the shaft.

You should not have to force the bearings onto the shaft as long as they are properly lined up. The bearings are self-aligning meaning that they can pivot in their cast-iron housings. If you need to change the angle of the bearing, you can insert a large screwdriver or the handle of a socket wrench into the bearing and use it to straighten the bearing out.

Insert the shaft one end at a time and tighten the setscrews firmly. **DO NOT** tighten the bolts that connect the bearings to the channels, they are pre-adjusted at the factory.

After the lower shaft is in place, install the spacer bar between the two channels. The end with a stud goes to the left. The nuts and bolts come attached to the spacer bar.

Install the back guard at the bottom of the channels with the hardware in bag TW6-4. Make

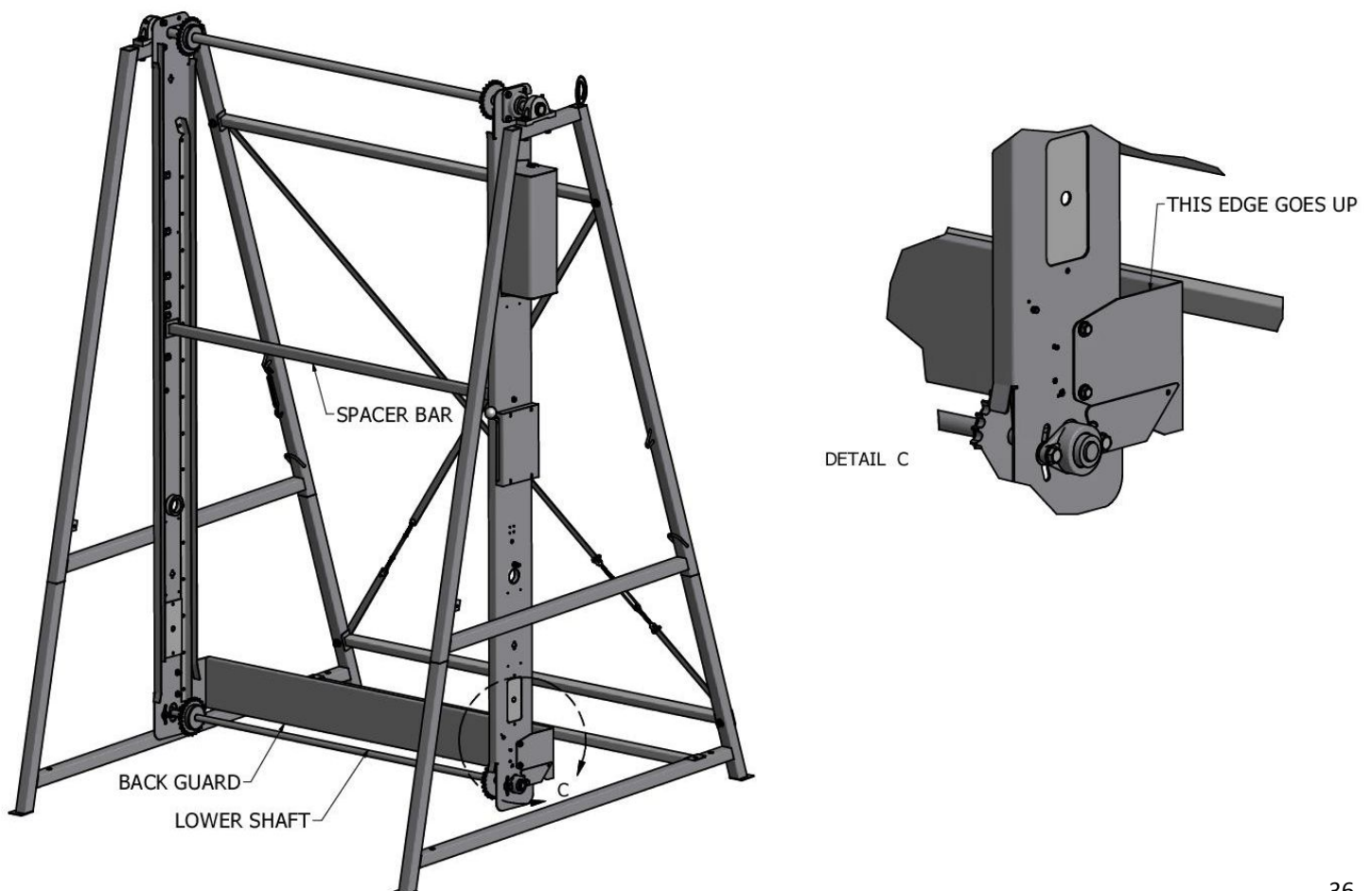

Main Channel Assembly

Install the angle-adjuster tube through the holes with plastic bushings in the channels.

The wheel is usually located on the right side of the Treadwall, but it can be on either side, depending on the location. Make sure there is good access to it. All of the hardware for the angle adjuster is located in bag M6-3

After the cables are installed and working, move the assembled Treadwall to its final location while it is still light enough to push around. If it is on a finished floor, slip rags or hand towels under the feet to prevent scratching.

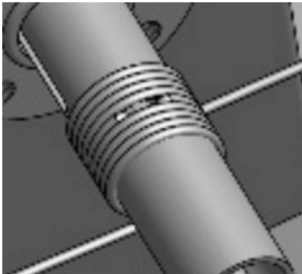
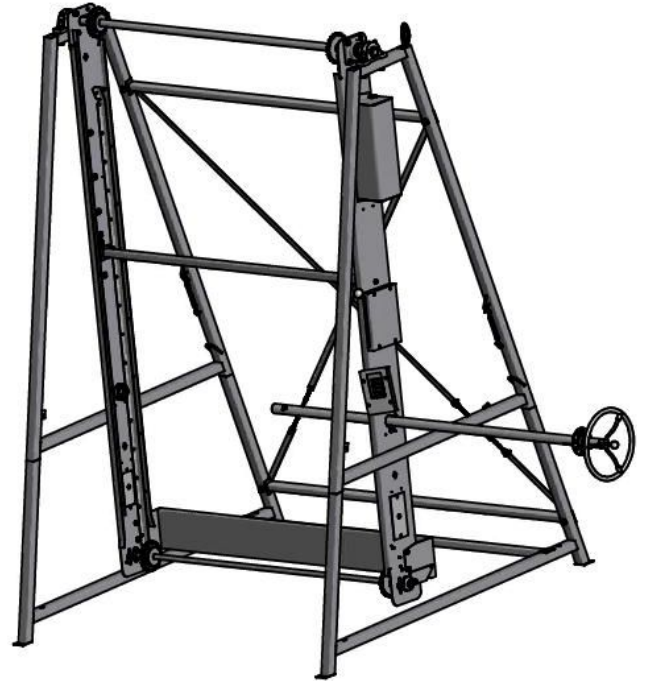

fig. 1

When you first uncoil the cables, you will see that there is a kink in the cable. The cables are attached to the tube by hooking this kink under a tab cut into the tube near each end (fig. 1). Note that the kink is not in the middle of the cable. There is a long end and a short end.

Attach the cable to the tube (by hooking the kink under the triangular tab) with the short end going towards the back. After you wind the cable, this end will actually be going towards the front of the machine.

Lock the tube from rotating by pushing one hole of the locking disk onto the stud on the channel. Wind the short end of the cable onto the tube in neat coils in a clockwise direction. Note in fig. 2 how the cable is wound so that the short end is near the outside end of the tube. *This is the right side of the Treadwall. On the left side, the cable is wound so that the short end is on the inside (fig.5).*

After about five coils, attach the cable to the front of the frame (fig. 3).

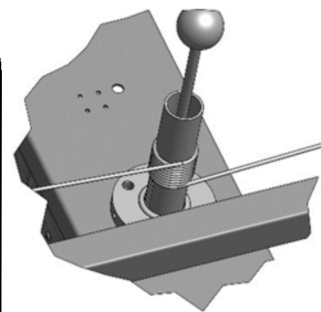

fig. 2

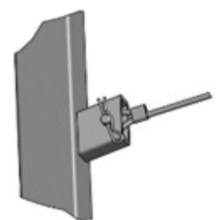

fig. 3

Main Channel Assembly

Wind the other end of the cable until it is the right length for the turnbuckle and attach it to the rear of the frame (fig. 4).

Tighten the turnbuckle and get all the coils nice and tight. Install the left side cable following the same procedure making sure to wind the cables in the correct direction (fig. 5).



fig. 4

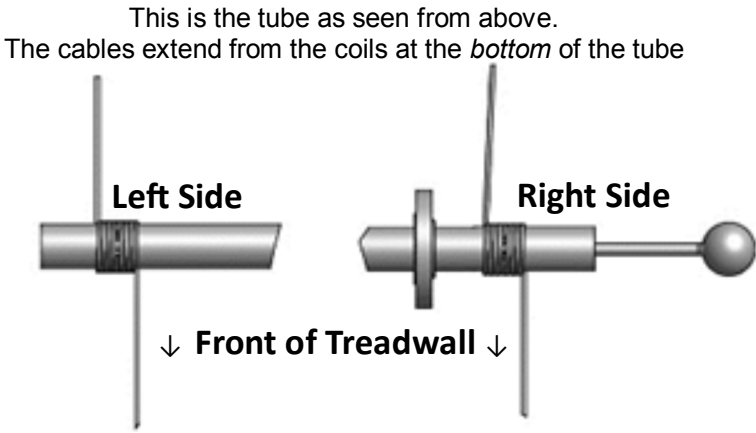
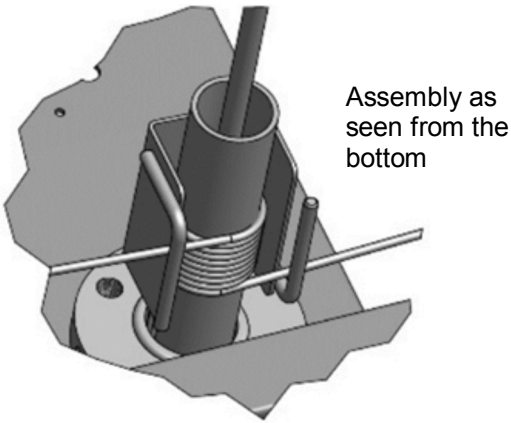

fig. 5

The wall angle can now be changed by rotating the wheel back and forth. To eliminate stretch in the cables, wind the wall all the way forward and press down hard on the cables (or strike down on them with a hammer or piece of wood). This will not damage the cable, but will stretch them somewhat so that you can tighten the turnbuckle some more. Angle the wall all the way back and do the same thing.

Finally, install the cable guard (fig.6). Hook the cable guard onto the front cable, and loosen the turnbuckle (while maintaining tension on the coil) until you have enough slack to slip the rear cable under the other hook. If the cable guard cannot be installed properly, the cable is most likely wound in the wrong direction and must be re-wrapped.

Check that the cables are neatly coiled, and tighten the turnbuckles firmly.



Assembly as seen from the bottom

fig. 6

Main Channel Assembly

Before raising the shroud into position, make sure that the front two flange-bolts on each square bearing are quite loose. There should be a 1/4" gap between the head of each flange-bolt and the bearing.

Each square bearing should have only 3 bolts at this point. The top rear bolt will be installed once you get the shroud in place. Have these two bolts ready as you lift the shroud.

Use the ladders to raise the shroud and slip the curved slots under the two front bolts.

Line up the rear top holes in the square bearings and shroud then slip in the flange-bolts.

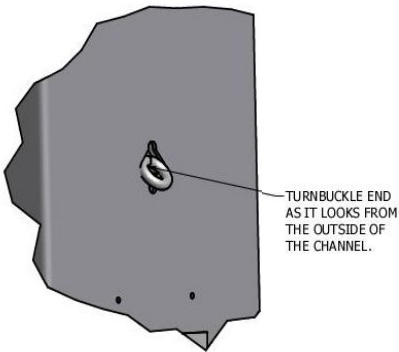
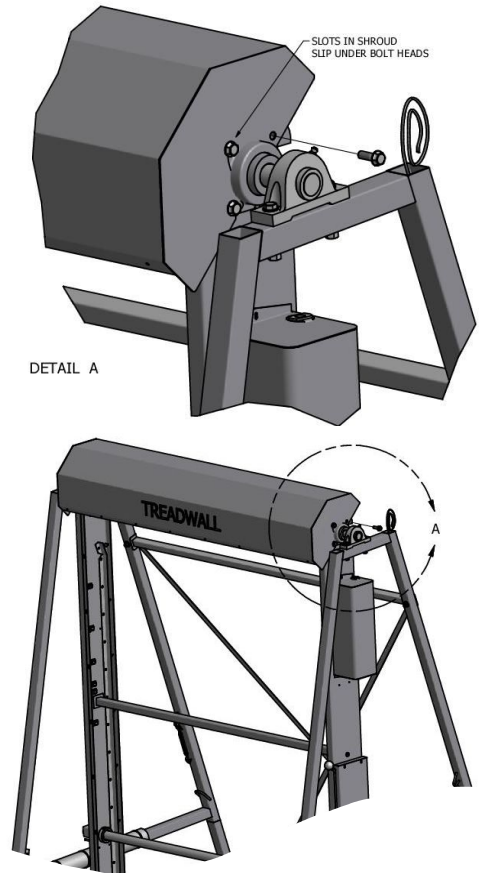

The internal x-braces cross on either side of the spacer bar and angle tube - one in front and one in back. The X-bracing slots are located just above the lower rectangular holes and below the square bearings at the top of each channel.

Adjust the turnbuckles to almost their full length before installing them.

The round eyes at the ends of each x-brace fit into special slots in the channels. You slip them in vertically and then turn them to lock in place. Insert and rotate the top welded eye first and then the eye on the turnbuckle into the lower slot on the opposite channel.

Once they are installed, make the turnbuckles equal length and finger tight. Do not over-tighten, you can squeeze the channels together preventing the panels from sliding smoothly through the channels.

There are lock-nuts on the turnbuckles which should be tightened very firmly to prevent them from loosening up.



Main Channel Assembly

Bring the wire from the top of the right A-frame through the grommet near the top of the right channel and down through the wire clips. Inside, about a foot below the grommet, plug it into the main wiring harness.



Mount the counter-timer on the right channel to the four small holes below the speed control - with the provided screws and nuts. The sensor wire and power wire are pre installed and plug directly into the rear of the counter.



There are three magnets packed with the right channel that must be placed on the upper shaft, just to the right of the small sprocket. Place them flat side down and they will stay on by magnetic attraction.

The sensor which is mounted just below the shaft on the inside of the channel should be adjusted so that the magnets pass about 1/8" above the sensor.

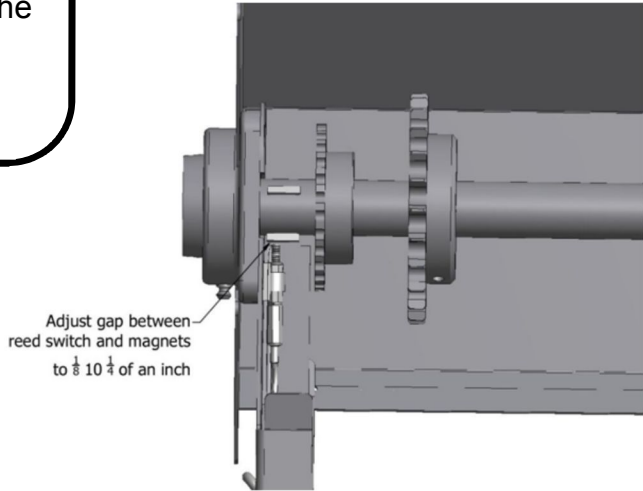
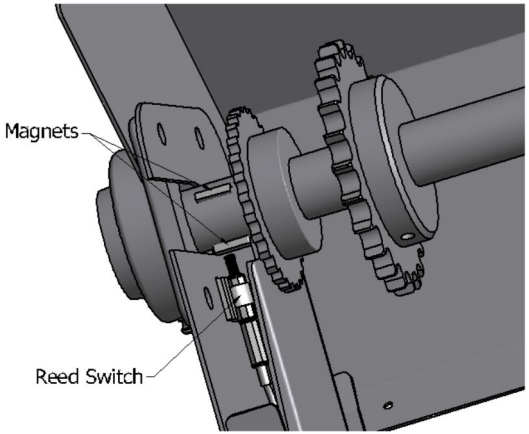

Main Channel Assembly

Pushdown Bolt

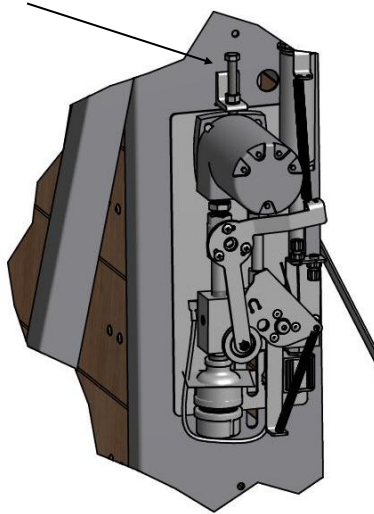

Remove the cover at the top of the right channel.

The hydraulic pump is mounted in slots so it can slide up and down. Make sure it is as high as it can be.

Install the drive chain between the pump sprocket and the main shaft as shown. A master-link is provided to connect the chain.

Once the chain is attached, lower the pump to take up the slack. There is a long push-down bolt above the pump. Adjust it down far enough to take out the slack in the chain, but don't make it too tight. Too much tension will make the

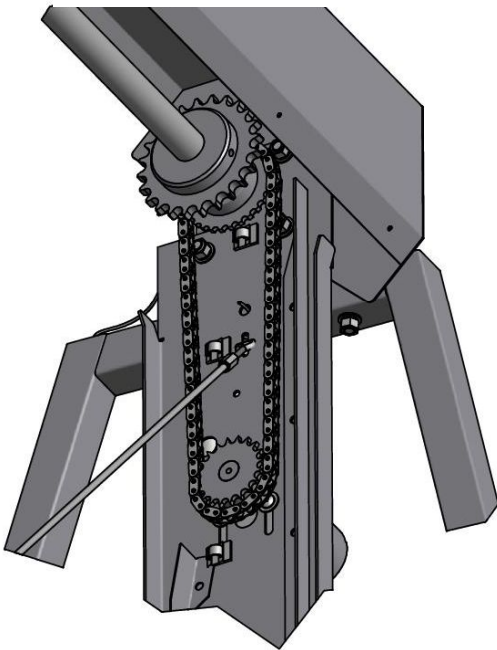

To disassemble the master-links use a pair of pliers or a flat blade screw driver to press and slide the retaining clip along the side plate in the direction opposite the open end of the retainer clip.

To install the Master-links assemble them as shown in the diagram below. The retaining clip must fit into the small grooves on the master-link. Then, press and slide the retaining clip into position towards the open end of the retaining clip.

When correctly installed the retaining clip is solidly in the grooves of the master-link laying flat against the side plate.

The same style master-link is used on the drive and main

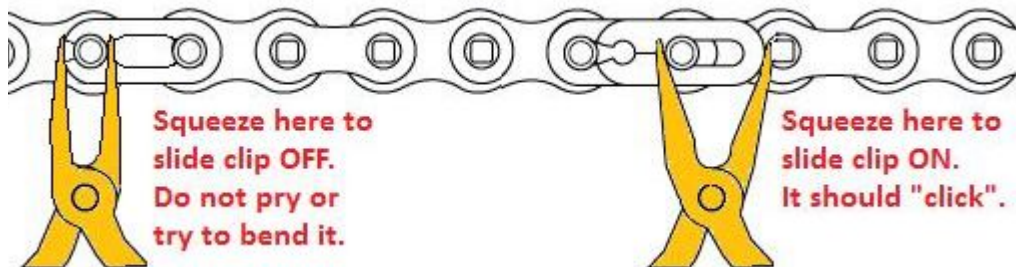
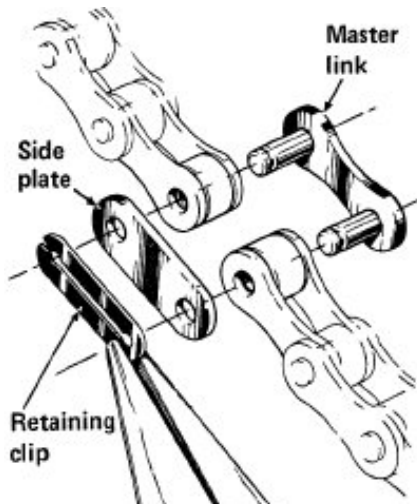

Squeeze here to slide clip OFF. Do not pry or try to bend it.

Squeeze here to slide clip ON. It should "click".

Main Channel Assembly

To install the main chains, Set the speed lever to 0, then drape one chain over the large sprockets under the shroud with the tabs facing out. The second half of the chain will need to be attached, be careful to attach the correct ends of the chain together to maintain the 6" spacing of the tabs. (fig. 1) Bring the other end around the sprockets on the lower shaft. Attach the master-link.

When you are doing the second chain, be aware that the tabs must be synchronized between the two chains. When a tab on one chain is level with the spacer bar, the tab on the opposite chain must also be level. (fig. 2)

If the chains are not synchronized, the panels will be crooked and jam.

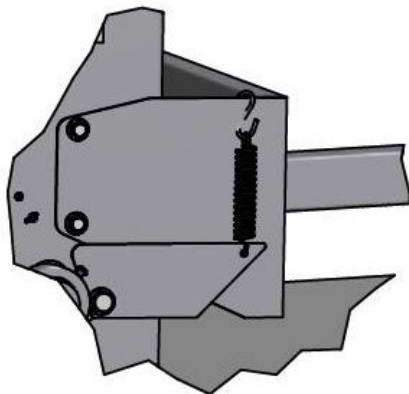
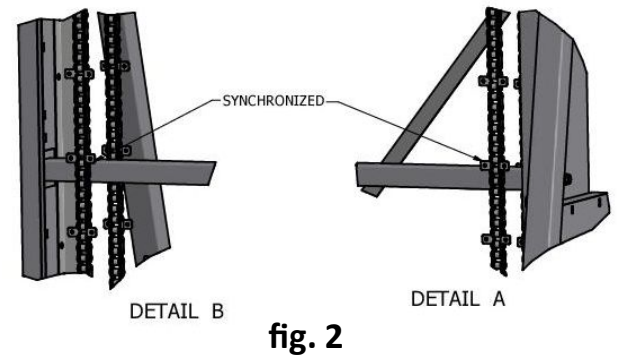
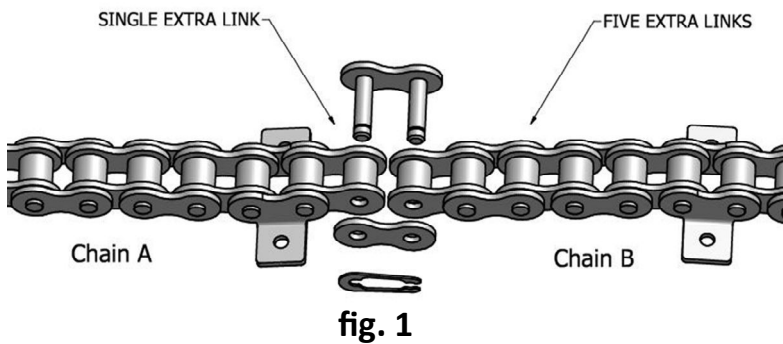

Strong springs hold the chains in tension.
 You will find these in bag TW6-5
 Use the enclosed cord to pull up on the spring and attach the s-hook to the back-guard

Main Channel Assembly

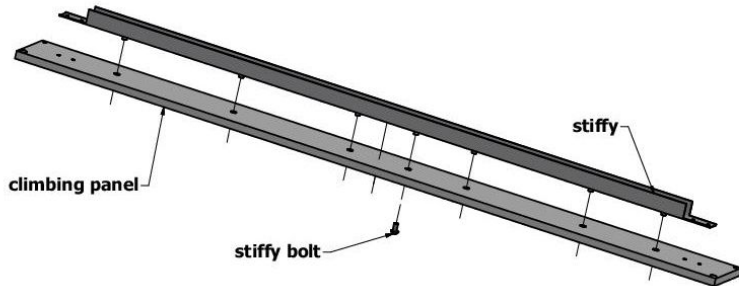

Each panel has a metal stiffener that must be mounted on the back (smooth side) before installing the panel onto the Treadwall.

Place the panel face down on a piece of cardboard, line up the stiffy, and press it into place - stepping on it with your foot if necessary.

A short round-head "stiffy bolt" is screwed firmly into the middle hole from the front

The best tools to use for installing panels: A battery powered electric drill with a #2 Philips bit and a socket wrench with a 3/8" socket. Do not overtighten the screws. If your drill has a clutch, use a low setting so that the head of the screw seats down but does not dig into the panel.

Notice the plastic wear buttons in the corners of the panel. The buttons in the front of the panel should always be at the TOP corners of the panel. The final hole pattern on the climbing surface should create a diamond shape. Pay attention when putting the panels in to alternate between having a wide or narrow gap between the right most holes.

After installing the first panel, pull down on the chains to rotate the panel completely around the circuit. As it passes the lower shaft, adjust the sliding sprocket to the proper width so that the panel passes easily without binding. No set screw is used for this sprocket.

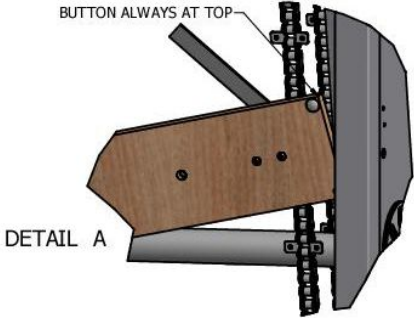
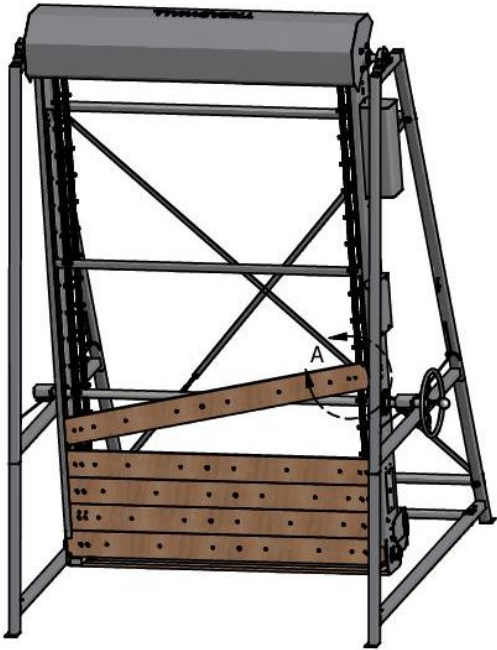

Main Channel Assembly

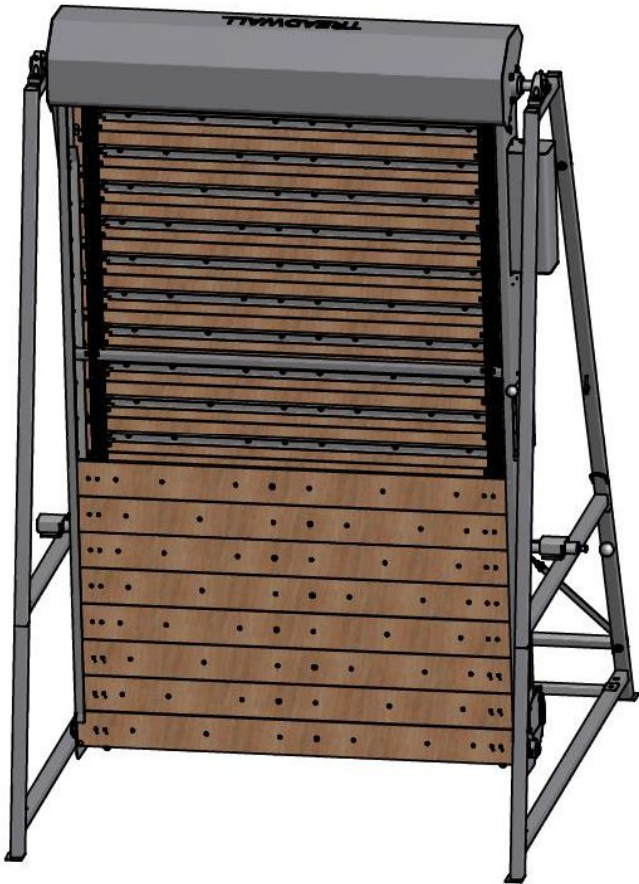

Continue installing panels, alternating the hole spacing. Use the speed control lever to control the descent of the panels.

As you install panels they will move down by their weight. There will come a point where they start to move up of their own, and then you will have to push them down - harder and harder as you put more on. This is because there are more panels at the back of the wall - heavier than the panels in the front.

When this happens, insert blocks of 2x4 wood between the bottom panels as shown to jam the wall and prevent it from backing up. Use two blocks - one at each end of the panels.

The last three panels cannot be put in the same way. They must be put in from the bottom, slid up to meet the other panels, and bolted on.

Remove the covers from the rectangular access holes at the bottom of the channels so you can get to the inside when putting on these last three panels. Leave the last panel off until the end of the installation - after the climbing holds have been put on and everything has been tested according to the check list at the end of these instructions.

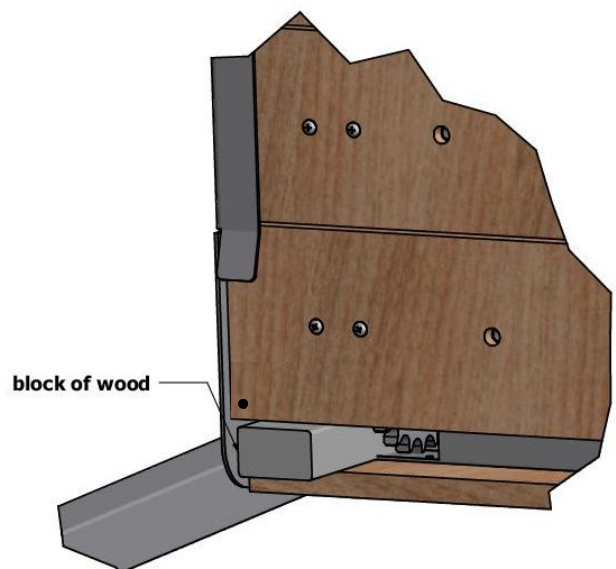

Main Channel Assembly

Put on the post pads under the cables as shown and secure with 4 wire ties. The ties are spaced evenly along the length of the post pad starting 2" from each end and secured with moderate tension. Line up the buckles on the cable ties with the seam, orient them to the bottom of the rail, and trim off the excess tie.

Slide the mat under the wall to the back of the A-frame with the shortest fold to the rear.

The mat is held in place by loops, Buckle these around the front legs

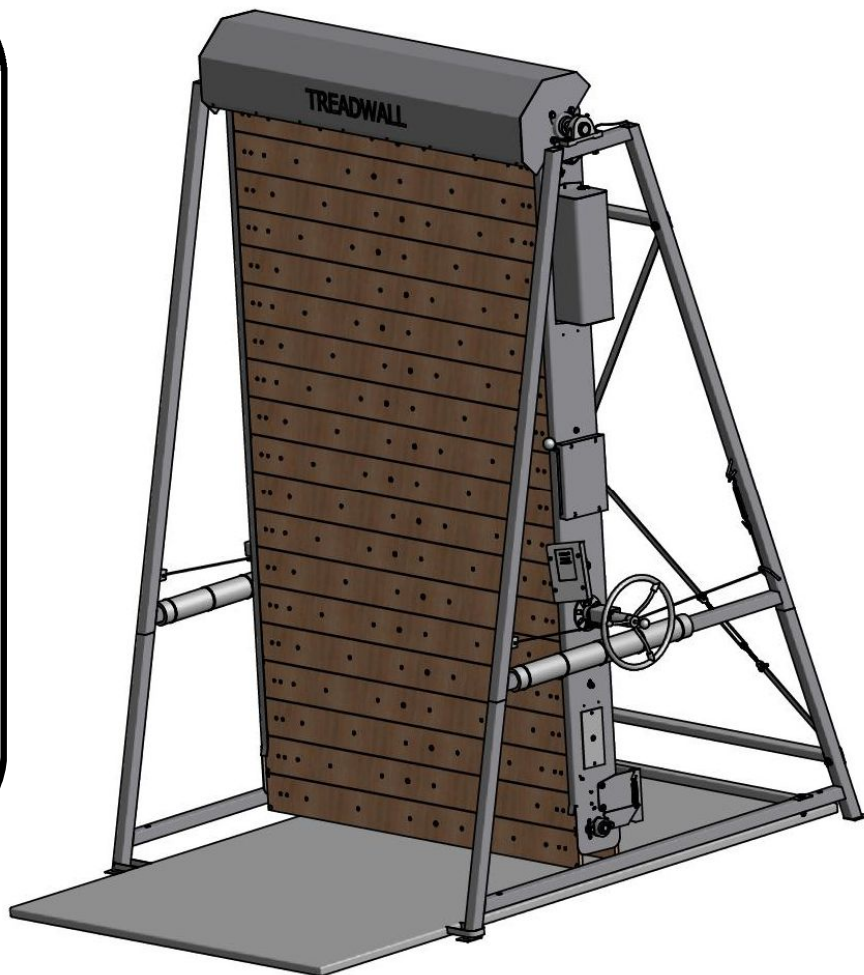

This finishes the installation except for putting on the climbing holds, Ladder Line, and installing the last climbing panel.

Install the Ladder Line first. Followed by the climbing holds, there is a short guide in this manual (Page 7 and 8).

When everything is in place test the wall at different angles and speeds. Finally, put on the last panel and cover the access holes.

Main Channel Assembly

Final Tests

Before installing the final panel, inspect the inside of the Treadwall:

- 1) **There may be air trapped in the hydraulic oil after transport: this will cause the unit to run quite rough (cavitation) until the air is slowly released into the reservoir. The amount of air trapped varies, but it may take 10-15 minutes or more of use to begin smoothing out. The system will get smoother and smoother over time.**
- 2) Make sure the timer-counter is working properly. If it does not count feet as the wall is moving, check that the magnets and sensor are properly installed and adjusted
- 3) Check the auto-stop function. Start climbing at a moderate speed. If you stop moving up, the wall should continue down and stop moving downward when your foot reaches the bottom of the wall and triggers the micro switch at the bottom of the right channel. Do this test at all the angles. The micro switch is pre-set at the factory, but it can be adjusted for sensitivity if required by loosening its small mounting screws and pivoting it.
- 4) Check the drive chain at the top of the right channel. The slack should be adjusted out of it, but it should not be too tight. After climbing for a few minutes, some slack might develop which should be adjusted out. This chain will stretch over time, and should be adjusted after about a month of service. There is an inspection hole in the channel to check the chain so that a climbing panel will not have to be removed.
- 5) Check the x-bracing rods inside of the channels. They should be equally adjusted (the turnbuckles should look the same) and finger tight with the lock-nuts tightened securely. The plastic tubing cushions the x-bracing from the adjuster pipe and spacer bar to prevent noise. Make sure they are properly adjusted.
- 6) Check that the chains are properly synchronized. The climbing panels must be parallel to the spacer bar. If the panels droop down on one side or the other, the chains are out of sync. We have an easy way of fixing this, so give us a call (800-707-

Glossary

- Angle**.....The position of the center section of the Treadwall in relation to a vertical wall
- Channels**Long metal pieces on either side of the Treadwall, where the panels slide
- Digital Counter**....An electronic display which tracks the climbers progress
- Hold**.....The plastic or wood attachment that a climber uses to hold or stand on
- Ladder Line**A wooden climbing hold that allows for easy and aerobic climbing
- Mat**A foam pad which protects falls, placed under the Treadwall
- Panel**A wood board that forms the surface of the Treadwall
- Shroud**A cover at the top of the Treadwall
- Speed**.....The rate at which a climber moves the wall down
- Stiffy**.....A metal reinforcement behind the Treadwall panels

Treadwall® Limited Warranty

1. WHO IS COVERED?

The original purchaser of any model Treadwall (“Original Purchaser”) may only enforce this warranty.

2. ORIGINAL PURCHASER OBLIGATIONS

- a. The Original Purchaser assumes full responsibility that this Treadwall purchased meets the specifications, capacity and other requirements of the Customer.
- b. The Original Purchaser assumes full responsibility for the condition and effectiveness of the operating environment in which the Treadwall is to function including spatial considerations.

3. HOW LONG IS THE WARRANTY?

According to the following schedule, Brewer's Ledge Inc. warrants to the Original Purchaser of its Treadwall that under normal maintenance the Treadwall will be free from any defect in materials or workmanship.

For M4, M6, Kore Commercial models:

Structural Steel Frames and Welds:

Ten years - parts and labor and freight.

All other components except cords, floor mats and vinyl products:

One year - parts, labor, and freight.

Cords, side covers, floor mats:

Ninety days - parts, labor, and freight.

For M4 and KORE Home/Residential models:

Structural Steel Frames and Welds:

One year - parts and freight.

All other components except cords, floor mats and vinyl products:

One year - parts and freight.

Side covers, floor mats:

Ninety days - parts, labor, and freight.

4. WHEN DOES THE WARRANTY BEGIN?

Warranty begins from date of delivery to Original Purchaser or date of installation in the case of factory assembly. In the case of either Demonstration or Trial Agreement and related purchase, the warranty begins from the date of the original delivery.

Treadwall® Limited Warranty

5. WHAT IS NOT COVERED

- a. Normal wear and tear is excluded from this warranty. No warranty shall be provided in the event the Treadwall is modified by original purchaser, for parts not approved by Brewer's Ledge Inc., or for warranty-related service other than by personnel authorized by Brewer's Ledge Inc.

- b. Damage incurred by negligence during movement, assembly, or breakdown of the Treadwall by the Original Purchaser or personnel contracted by the Original Purchaser is excluded from this warranty. The sale of special tools and instructional materials to the Original Purchaser and any training of the Original Purchaser's staff by Brewer's Ledge Inc. related to the movement, assembly and break-down of the Treadwall does not imply any warranty against Original Purchaser negligence and does not void this exclusion. Brewer's Ledge Inc. reserves the sole right to determine the origin of damage as related to this provision.

6. LIMITATION OF DAMAGES AND IMPLIED WARRANTIES

- a. Except as provided herein, Brewer's Ledge Inc. makes no express warranties; implied warranty of merchantability or fitness for a particular purpose is limited in its duration to the duration of the written limited warranties set forth herein.

- b. In no case shall Brewer's Ledge be liable for any special, incidental, or consequential damages based on breach of warranty, breach of contract, negligence or any other legal theory. Such damages include but are not limited to, loss of profits, loss of use of the equipment or any associated equipment, the cost of capital, the cost of substitute equipment, facilities or services, downtime, the claims of third parties, including customers, and injury to property.

This limitation does not apply to claims for personal injury where such limitation would be a violation of the applicable law. Some states do not allow the exclusion or limitation of incidental or consequential damages, so the above limitation or exclusion may not apply to you.

7. TERMS OF WARRANTY

The terms and conditions of this warranty are applicable as between Brewer's Ledge and Original Purchaser to the sale of Treadwall equipment to Original Purchaser.

STATE LAW RIGHTS

This warranty gives you specific legal rights, and you may also have other rights, which vary, from state to state.

Contact Information



Website

WWW.BREWERFITNESS.COM

Email

SALES@BREWERFITNESS.COM

Address

Please come by for a visit some time!

87 York ave.
Randolph, MA 02368

Phone

1-800-707-9616