

## COMPLETE OWNERS MANUAL

# TREADWALL♦ Model M4 V

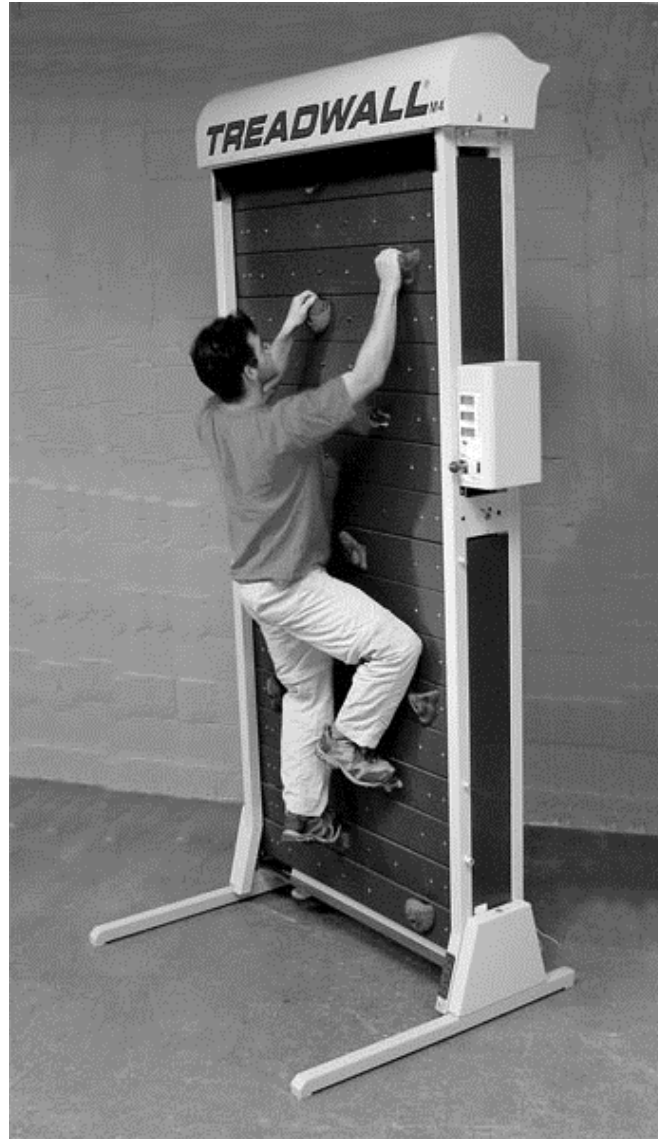

**BREWER**  **FITNESS**



# INTRODUCTION

This book is an important part of your Treadwall® package.

Vertical movement is a recent option in fitness and training, and often misunderstood. Simply installing equipment will not guarantee a strong program. A successful program needs people who understand its potential, benefits and how to use it as a fitness tool.

Sometimes, when we visit clubs with Treadwalls, we hear the comment “Oh yeah, the Treadwall. I’ve tried that. It’s a real workout!” True, the Treadwall can be set to give an upper-body challenge that will soon exhaust the fittest person, but it is also capable of delivering a remarkable aerobic burn that anyone can “enjoy.”

You need to focus on trainers who look at the Treadwall with a creative eye, understand that they have found a highly effective activity adaptable to all levels of fitness, and who integrate vertical movement into their own routines as well as their clients.

This book is designed to help managers, staff and trainers make the most of their Treadwall. It suggests ways to engage staff/clients and a reference tool to help design fitness programs. Many of the ideas are easy but effective. Others are more ambitious. They all can work!

*Jeff Brewer, inventor of the Treadwall, works out on the first prototype, fall, 1990*



## Choosing an Advocate: first crucial steps

When the Treadwall is first installed, it will be an unfamiliar item. Climbing will be a relatively new training activity for most. We recommend that a staff person be chosen as the main advocate for the product's introduction period. This person might take on the following responsibilities:

- a. Read through the manual and familiarize yourself with the Treadwall's operation procedures, use and set-up.
- b. Formulate a plan to integrate this equipment into your classes, personal training or general usage. Consider making announcements and sending out emails to promote the new addition to your member.
- c. Meeting with staff for the first month for weekly suggestions on new training ideas and get their feedback on the use of the equipment.
- d. Consider challenges, competitions (joining our Everest Program), fun ways to get your members hooked on Vertical Movement.

Another important first step is to consider carefully the location and positioning of your Treadwall. A location that is too visible - for example in the direct focus of members using CV equipment or walking in the entrance - may discourage people from climbing. Often simply rotating the Treadwall slightly will dramatically improve its



## THE FIRST YEAR:

### Suggestions for making the Treadwall work a success:

Developing an effective fitness program involves more than just placing a piece of equipment. To unlock the full potential of the Treadwall, the machine and vertical movement should be properly integrated into your facilities environment. (refer to the box above for suggestions)

### Important Basic Groundwork:

Staff should understand that vertical movement is a basic human activity, non-contrived and part of everyday life. It should be presented a positive addition to the facility

Climbing will often be perceived as challenging and intimidating activity. A staff locked into the value of vertical movement as a fitness tool is the key for changing this perception. Members should be actively encouraged to try the Treadwall and

consider it for part of their workout routine. We have found that people who are initially hesitant often end up being the biggest Treadwall fans.

**Introduce Treadwall to Staff:** Have them read this

During this introductory period, it is crucial that all staff learn how to operate the Treadwall and become familiar with the benefits of vertical movement. Being able to adjust the wall to best suit each person is key to making a Treadwall comfortable for anyone.

- 1) You should use the equipment yourself to get a first-hand look at how the workout makes you feel, learning to access angle/speed for a variety of abilities and to reap the benefits of vertical movement personally.
- 2) At first this equipment may be considered intimidating, but the more knowledge you can pass on to your members about training and benefits will help bridge the gap.
- 3) Check out all the different ways it can be used (varying hand grip, angle and body movement) --- to keep it engaging to the user. Be creative.

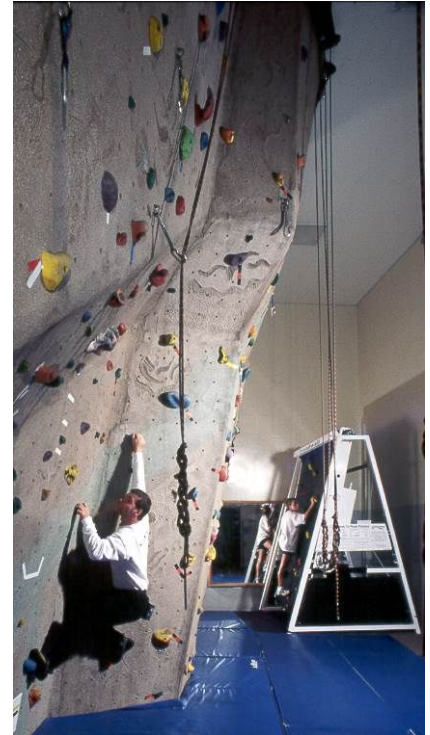

**The Benefits of Vertical Movement:**

Most fitness activities target isolated muscle groups, but vertical movement is different. Using a treadwall provides a full-body, non-repetitive exercise that can be adapted by the user for different goals. By adjusting the exercise patterns, angle and/or speed you can vary the amount of cardiovascular endurance, upper-body strength and grip training you perform for a customized experience. Working out on a Treadwall is fun and mind-engaging. In terms of focus and mental involvement, climbing has no peer. The activity requires constant decision-making and concentration. This promotes a quick motor response and muscle recruitment. Technique, balance and core strength interplay and climbers often develop a heightened sense of body awareness and confidence in their daily lives.

The Treadwall can be used by itself by performing intervals, for circuit training with other equipment or longer periods for pure endurance. It is a low-impact full body workout which makes it an ideal complement to other fitness activities and sports. It can be used as a warm up, cool down or a high intensity programming.

Customize it to suit YOUR needs and GOALS.

**Basic Operations:** (refer to quick start sheet at the end of this document)

- 1) Changing angles,
- 2) Choosing different routes
- 3) Creating different types of workouts (aerobic, strength, flexibility) You can find helpful programming ideas on our website: [www.brewerfitness.com/index.php/info/training](http://www.brewerfitness.com/index.php/info/training)

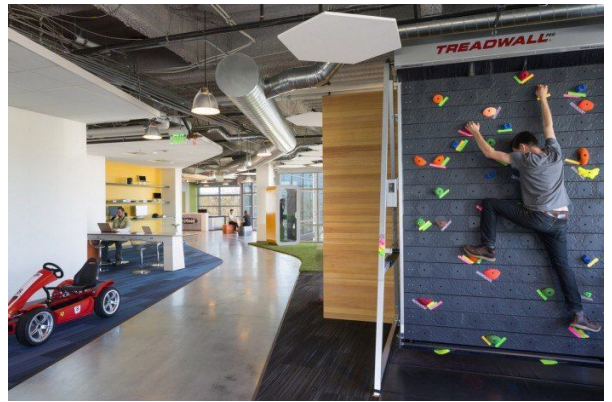

**Make sure the holds are set in the easiest possible routes.** Spend some time reviewing and fine tuning hold positions. (Using the routesetting guide on page 7 and 8) This is a good opportunity for staff to learn and discuss route setting:

- What happens when you turn a hold to a different orientation?
- How does the angle of the wall affect the way the different types of holds work?

**Make strong attempt to get all members to try the Treadwall for at least one workout session.** They should try it at a positive angle first so they can get familiar with the balance and motions involved. Try the workout on the *Quick Start* with them if you need a reference.

- Emphasize controlled, smooth climbing and attention to balance and footwork.
- Suggest short workouts to start, which will complement their current workout routine

**Setup a Mt. Everest club challenge for staff and members.** Perhaps use teams. (Brewer Fitness provides free Everest Club membership to the first three staff members to complete the challenge.

***The Everest Club:***

*Climb 29,028 feet on the Treadwall and you are eligible to join. You can find the Everest application and a training log to keep track of distances on our website: [www.brewerfitness.com/resources](http://www.brewerfitness.com/resources)*

***Special incentive:***

*Brewer Fitness provides free Everest Club Membership to the first three staff members to complete the Everest Challenge*

**Recognize the first members to start on Mt. Everest Club challenge.** Use the bulletin board to put up names and perhaps pictures.

## Continuing Education and Interest:

Set up a meeting with trainers to establish goals and training ideas for continuing to advocate use of the wall. The following are ideas for positive criteria:

- Cross-training for sports that emphasize forearm strength such as martial arts, baseball, swimming and tennis.
- Weight-loss programs. Focus on manageable goals, using easier positive angles. Emphasize smoothness over speed.
- For Cardiovascular try 15 minutes once a week or every two weeks in place of a treadmill.
- As a warm-up, especially for lifting. Suggest using ground-based training (hands only) for larger lifters.

**Once you feel it has become part of the scene at your facility.** Now that vertical movement is a stronger part of the workout landscape, it's time to get creative with special programs and combinations with other workout activities. Use Staff as resources for these ideas.

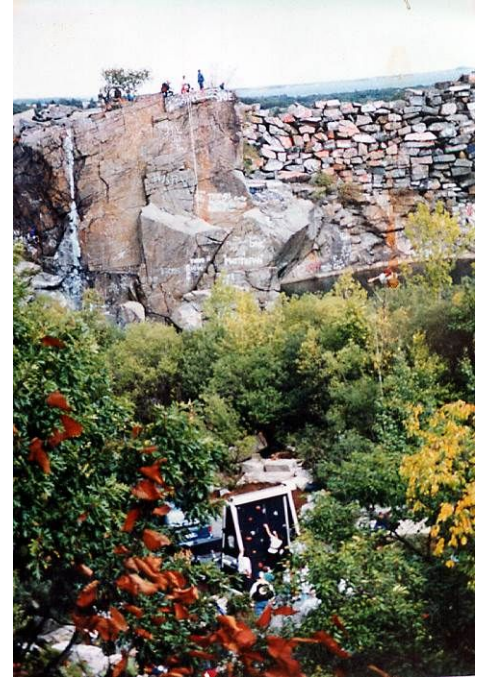

## Common questions about the Treadwall®:

# Q&A

### ***How hard is climbing on the Treadwall?***

Climbing on the Treadwall is as hard or as easy as you choose. The wall is customizable in difficulty by altering the speed, angle and route you follow.

### ***How fast can I climb on the Treadwall?***

The Treadwall is easily adjusted via the speed lever. In addition, the auto-stop system will keep pace with your stops and starts. We recommend starting off climbing at a slower controlled pace, focusing on smooth movement.

### ***How does the Treadwall work?***

The Treadwall operates by the weight of the climber. There are no electric motors. A hydraulic brake controls the speed of descent. The Treadwall cannot move after the climber steps off.

### ***How long should I climb for?***

This depends on your objectives. Test out various methods and take a look at our training section:  
[www.brewerfitness.com/index.php/info/training](http://www.brewerfitness.com/index.php/info/training)

### ***Will the hold pattern get repetitious?***

Eventually, but it takes much longer that you might expect. The Treadwall has no beginning or end, and it continually presents you with new challenges and possibilities. It is simple to set holds in other places and change the climb completely.

### ***Do I need special shoes to climb the Treadwall?***

No. Any well fitted athletic shoe will do quite well. However, special climbing shoes are more enjoyable to climb in. Climbing shoes are very close fitting with a special flat sole of special 'sticky' rubber. They are quite expensive. Karate shoes are a good inexpensive alternative.

### ***Can anybody use the Treadwall?***

Almost anyone can perform vertical movement. Anyone with a serious physical problem should consult with their doctor, and people with very long fingernails should think twice. We also suggest taking off your rings before climbing.

### ***Can you be too old to climb?***

Maybe, but we have reports of people well into their 70s who enjoy climbing on the Treadwall. One climber 72 years old recently completed the Everest challenge (29,028 ft.) - for the second time!

### ***Does everyone like it?***

Most people who try the Treadwall love it. Some of the biggest fans are people who start off saying "I don't think I'd like that." Everyone should be encouraged to give it a try.

### ***I have never done that. Will it take me long to learn?***

Never climbed? - not likely. Most children spend many happy hours climbing play equipment and trees. For adults, climbing on the Treadwall recaptures much of that simple joy and natural vertical movement.

### ***What kind of bodies does Vertical Movement build?***

Climbing and gymnastics are similar, promoting muscle tone, flexibility and endurance with increased agility and body awareness. Your body will respond by burning fat, creating a lean muscle structure and increasing bone density

***Do serious climbers like the Treadwall?*** Yes, it is a perfect endurance training tool, all the way from elite climbers to a novice.



# ROUTE SETTING AND HOLDS

The climbing holds provided with the Treadwall are universal to all climbing walls. They come in various colors, textures and materials can be set up in any number of ways by orientation or placement to provide new and different routes.

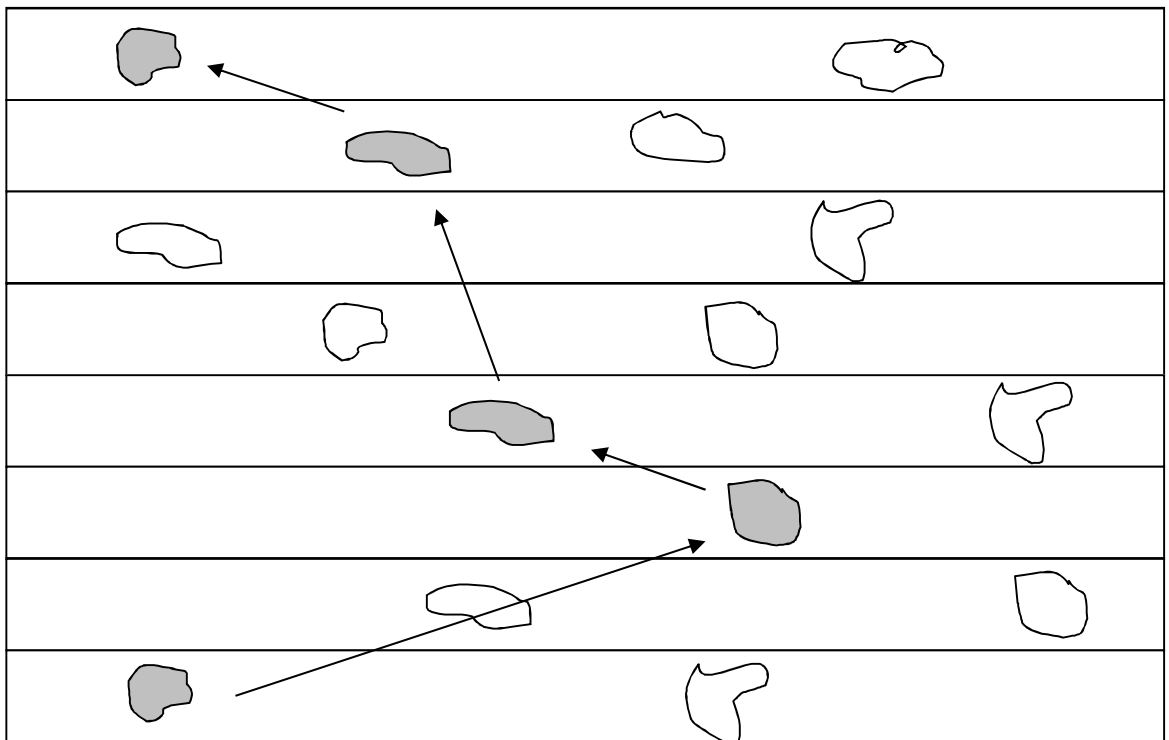
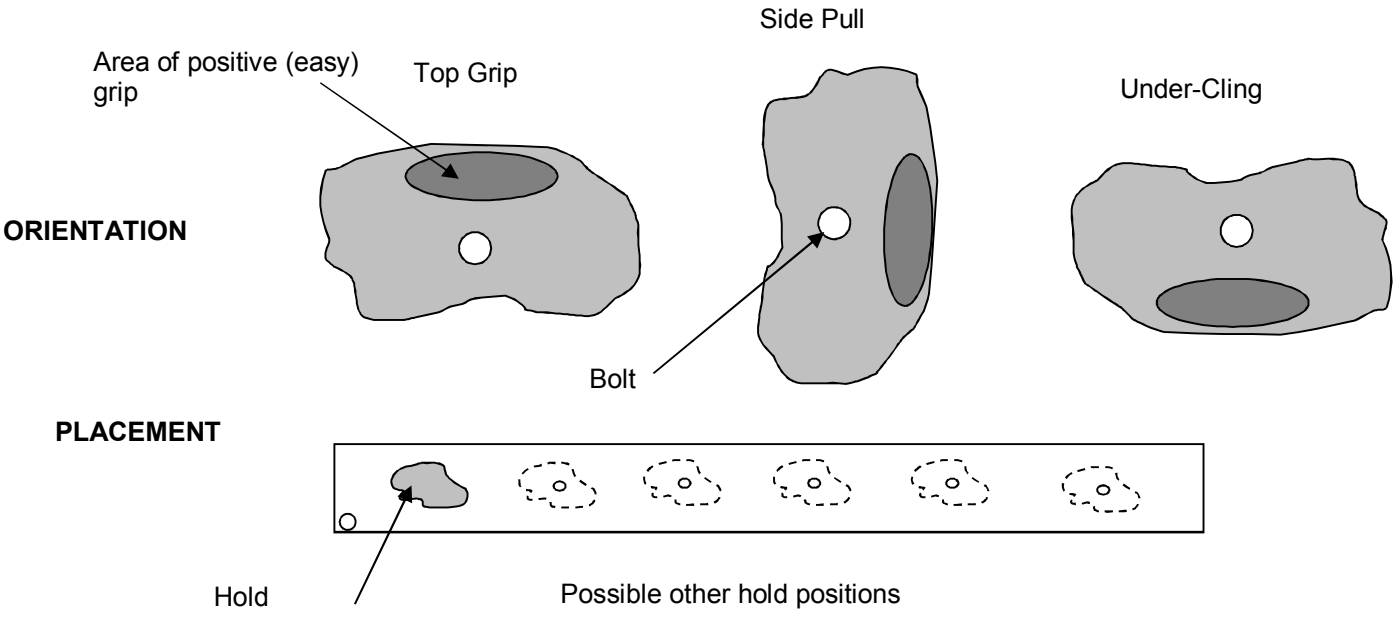

**The Treadwall set you have received is specially designed for the Treadwall.** There are 40 holds divided into 3 color groups, and each hold has an orientation arrow and a number. This allows on-line route sharing and exchanges. There is no large difference in difficulty between the set (you will find a routesetting app on our website: [www.brewerfitness.com](http://www.brewerfitness.com))

- The **Green group** is more uniform and is the easiest size to use.
- The **Orange group** has more surface shape and finger positions.
- The **Red group** has a third selection of hand positions and choices, but increases in difficulty

### Setting patterns

Start with one color. For example, use red holds spreading them out over the length and width of the wall. Test climb while bolting them on to make sure that the workout will be reasonable. Important: Each hold must be completely on its panel. Do not allow any holds to overlap the space between two panels or the wall will not rotate properly.

To start, orient most holds with the positive grip upward (easiest position), but look for places where variety can be added. Turning some of the holds will suggest a side-pull orientation. Turning others up-side-down will provide an interesting "undercling" movement (promoting more emphasis on the bicep and lower trap).

After establishing an easy single color route, fill in with the other holds. Again, most of the holds should be placed with the easy side up, and spread out over the whole width. Avoid clustering the holds in adjacent holes and too many in one section leaving big "blank" spots as this can make it harder to use.

With a few holds left, climb your route a couple of times to find any hard spots. Try climbing up just the left side, and just the right. Try elimination routes (avoid using reds, for example, or use just oranges) to see if they are possible. Use the last holds to fill in any obvious gaps.

### Route setting guidelines

- Emphasize non-repetitive movement and reaching.
- Create lateral movement.
- Always keep one really easy route.
- Use fewer big holds rather than many smaller holds.
- Plan routes with a purpose - flexibility, underclings, footwork, etc.

### Programming tips

- To change the route it is not necessary to take all the holds off. It is amazing how the wall will change if you move a few holds around or even if you just rotate some of the bigger holds.
- Establish a schedule for changing the routes.
- Try to introduce new holds on a regular basis. This can be done through Brewer Fitness website or a number of hold manufacturing companies. Some size restrictions apply - call Brewer Fitness for details 781-961-5200
- Publicize new routes. Use member's bulletin board to post changes.
- Use members to help with route setting. Start a "climbing club" to create a sense of purpose and provide knowledgeable people to keep routes fresh.

## SAMPLE HEIGHTS – AROUND THE WORLD

30'	Typical street lamp
58'	Texas School Book Depository - 6th floor
190'	Niagara Falls (American Side)
302'	Statue of Liberty
555'	Washington Monument
607'	Space Needle, Seattle
642'	Top Span, Astrodome roof.
984'	Eiffel Tower, Paris
1250'	Empire State Building, New York
1454'	Sears Tower, Chicago
2,717'	Burj Khalifa (tower in Dubai)
3200'	Angel Falls, Venezuela
4610'	Mt. Vesuvius, Italy
5117'	Devil's Tower, Wyoming
5267'	Mt. Katahdin, Maine
6288'	Mt. Washington, New Hampshire
7310'	Mt. Kosciuszko. high point in Australia
7569'	El Capitan, Yosemite National Park
8842'	Half Dome, Yosemite National Park
9570'	Mt. Olympus, Greece
11245'	Mt. Hood, Oregon
13766'	Grand Teton, Wyoming
14161'	Mt. Shasta, California
14495'	Mt. Whitney, high point continental US
14692'	The Matterhorn, Germany
16864'	Mt. Vinson, high point Antarctica
17011'	Mt. Arrarat, Turkey
18510'	Mt. Elbrus, high point of Europe
19938'	Mt. Kilimanjaro, high point of Africa
20220'	Mt. McKinley, high point of North America
22834'	Mt. Aconcagua, high point of South America
29028'	Mt. Everest, highest point in world



**“IMAGINE CLIMBING THE HEIGHT OF EVEREST AND TELL ME WHO WOULDN’T FEEL ACCOMPLISHED.”**

---

## RESOURCES:

1. [www.brewerfitness.com/index.php/info/training](http://www.brewerfitness.com/index.php/info/training)
2. Eric J. Horst – Climber. Performance Coach. Author has written multiple books on climbing training and exercises to improve strength to weight ratio
  - a. Training for Climbing
  - b.
3. Rob Pizem Site
4. Climbing Books/articles to reference

# Quick Start

1. Pull the knob on the angle mechanism out towards you to release the lock, then turn the wheel counterclockwise as far as it will go (ensuring you are at the most incline angle). Then line up one of the holes on the mechanism and push the knob forward ensuring it locks in place. This will allow you to begin at the easiest angle.
2. Be sure the speed lever is at zero before you begin
3. Step on the machine, begin to climb, and then pull the speed lever between 3 and 5 to begin slowly
4. For your first session, continue climbing for a few minutes (the timing is displayed on the screen) adjust the speed as you see fit during your session
5. Once you finish, ride the machine to the bottom and your foot pressure will activate the auto-stop sensor
6. **Access How You Feel?** (Elevated HR, Heavy Breathing, Muscles Burning)

## DID YOU LOVE IT?!?

Angle Mechanism

Speed Lever

Display Screen

Angles

### Beginner TW only-

**Warm up:** on Ladderline for 1 min (at a positive angle)

**Meat:**

- 1 min Ladderline, 1 min climbing holds
- Rest 1 min

\*\*Repeat x3

**Increase difficulty by:**

- A. Increasing speed
- B. Change the angle to vertical or overhang
- C. Do both and/or increase number of rounds

### Beginner Circuit -

**Warm up:** on Ladderline - 1 min (at positive angle)

**Meat:**

- 90 sec Ladderline
- 10 Push-ups
- 30 sec Ladder/30 sec climbing holds
- 15 squats
- 90 sec Ladderline

\*\*Repeat

**Increase difficulty by:**

- A. increase speed or change angle to vertical
- B. Increase number of rounds

## TREADWALL M4 SERVICE MANUAL

The Treadwall M4 comes in two models, the Base unit that is a vertical-only machine, and the Pro model that has a support frame allowing different angles for climbing. Except for the angle changing feature, the Base unit is the same as the Pro version, and most of the information in this manual applies to both units.

### GENERAL MAINTENANCE

The Treadwall M4 is a relatively maintenance-free machine, and requires little operational attention. Aside from an occasional chain adjustment and application of wax to the panel ends (see following pages), the only regular maintenance is attention to the climbing holds and climbing surface.

Because of the contact with the climbers' hands and feet, the climbing "holds" become unpleasantly dirty over time. We recommend the following cleaning procedure:

- Remove the holds that are to be cleaned.
- Just put them in a dishwasher with regular dishwashing detergent. After one cycle rotate and move the holds around to clean the other sides, and run it again.
- If there are residual areas of grime, scrub them with a toothbrush or other small brush.
- Replace the holds on your Treadwall.

It is neither necessary nor even desirable to remove all the holds at once when cleaning them. The Treadwall has about 40 holds, and a good plan is to clean 10 at a time. If this is done on a 2-week schedule, the entire set will stay in good shape, and the changes in climbing routes that naturally occur when the holds are replaced will keep the climbing experience fresh and interesting. Some owners purchase an extra set of 10 holds to switch out with the ones to be cleaned.

See the owner's manual for suggestions on route setting.

### PAINTING

The wall surface itself, of course, will show evidence of wear over time, due mostly to contact with users shoes. Normal cleaning maintenance will help, but eventually a re-painting will be in order. To re-paint, take off all the holds and mask the frame edges with masking tape. Roll on a coat of good quality latex deck paint, rotating the wall around to reach all the panels. A quart of paint will be plenty. Let it dry overnight before replacing the holds. Paint matching the original Treadwall finish is available from Brewer's Ledge.

## **DRIVE CHAIN ADJUSTMENT (See Drawing on Following Page)**

The Treadwall speed is regulated by a hydraulic pump located inside of the control box. To open the control box, remove the two small screws that lock it closed and carefully lift off the box.

The pump is driven by a chain from the top shaft, and occasionally the chain must be adjusted as it develops slack. You can remove a small side panel above the pump to check the chain and it's adjustment.

Notice the long threaded adjuster-screw above the pump The chain is tightened by turning this screw with 9/16" wrench, driving the pump downward. *Do not over-tighten the chain!* Just take out the excess slack and leave in a little play. If the chain is too tight, there will be a lot of resistance and the Treadwall will not rotate easily.

The chain will need to be checked after a couple of weeks of use – the initial break-in period – and should be checked every 6 months thereafter.

## **CABLE ADJUSTMENTS (See Drawing on Following Page)**

### **SPEED-CONTROL CABLE**

If the speed-control cable stretches, it will need a minor adjustment. If the control lever cannot slow the machine to a very slow pace, this adjustment should correct the problem.

- 1) Remove the cover to the control mechanism that is located high on the right side of the LadderMill.
- 2) Set the control lever to the slowest position (all the way down).
- 3) Examine the cam that controls the pulley-arm in the control mechanism. The cam has a small hole that should be aligned with the pulley on the pulley-arm.
- 4) If the cam-hole is not aligning with the pulley, it can be adjusted by turning out the cable adjuster
- 5) If there is not enough adjustment in this adjuster, there is a second adjuster inside the lever-box down below. If in the unlikely event that you need yet more adjustment, the cable can be tightened by loosening the clamping screw in the lever and pulling the excess cable through with pliers.

**HYDRAULIC CONTROL UNIT**

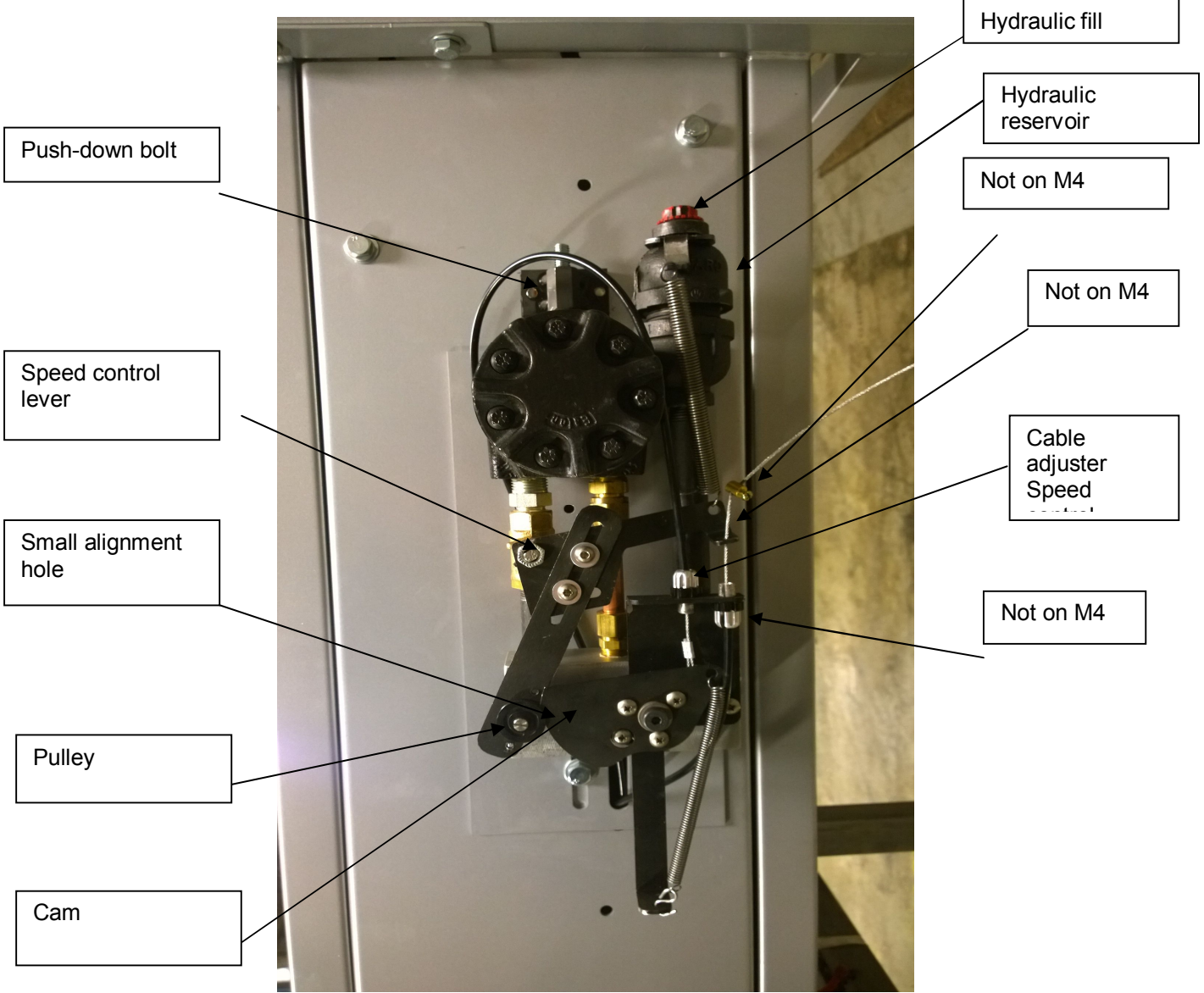

**SPEED CONTROL LEVER**

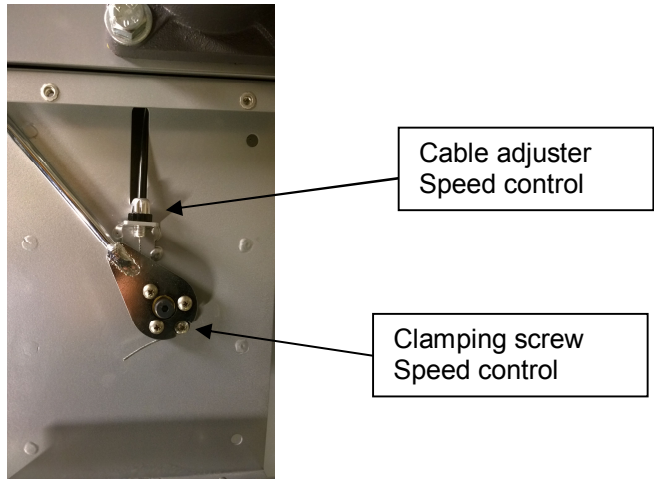

## PANEL LUBRICATION

The climbing panels slide down channels on either side of the machine which are initially waxed to provide a good sliding surface. If the wall seems sluggish – not sliding freely – the ends of the panels may be waxed to make them move easier. Simply apply a thin coat of paste wax (butcher's wax is ideal) with a pad of cloth to the ends of the panels at the bottom of the machine.

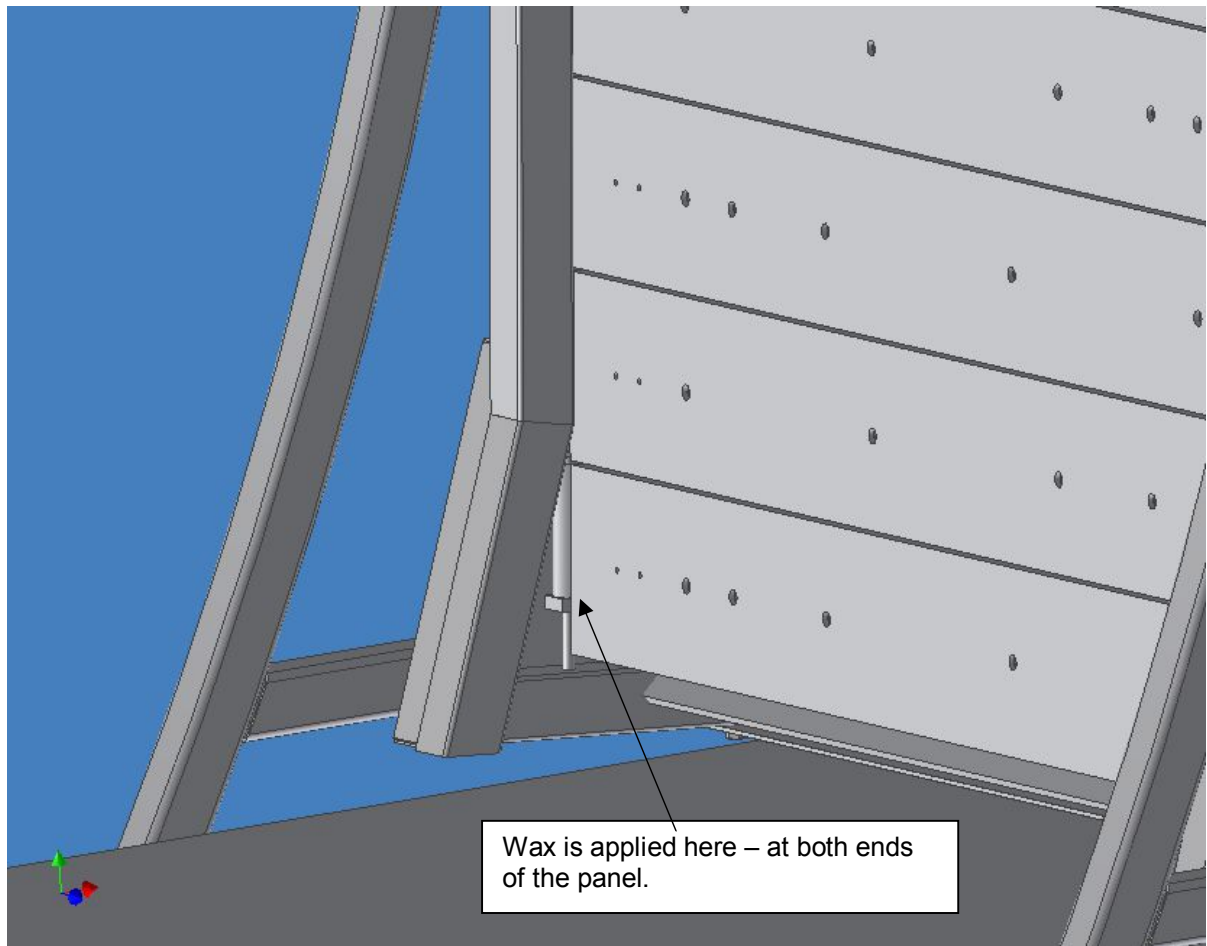

This is very quickly done with two people – one pulling the wall around while the other wipes on the wax. This maintenance is needed very infrequently, especially after the first couple of applications.



## MICROSWITCH ADJUSTMENT

The Auto-Stop brake system is operated by a microswitch at the bottom of the right channel-frame. At the bottom of the channel, a hinged actuator presses in against the switch by the force of the climber's foot, and the wall stops. If the brake doesn't operate properly, the microswitch may need adjustment.

The adjustment is made by carefully bending the switch-arm with a pair of needle-nose pliers. Remove the hiding panel at the bottom of the channel by lifting it up and out. Locate the switch and actuator. The switch should give a little click when the actuator is pushed in by  $\frac{1}{2}$  to  $\frac{2}{3}$  of its total travel. Carefully bend the arm of the switch until it clicks at the right point.

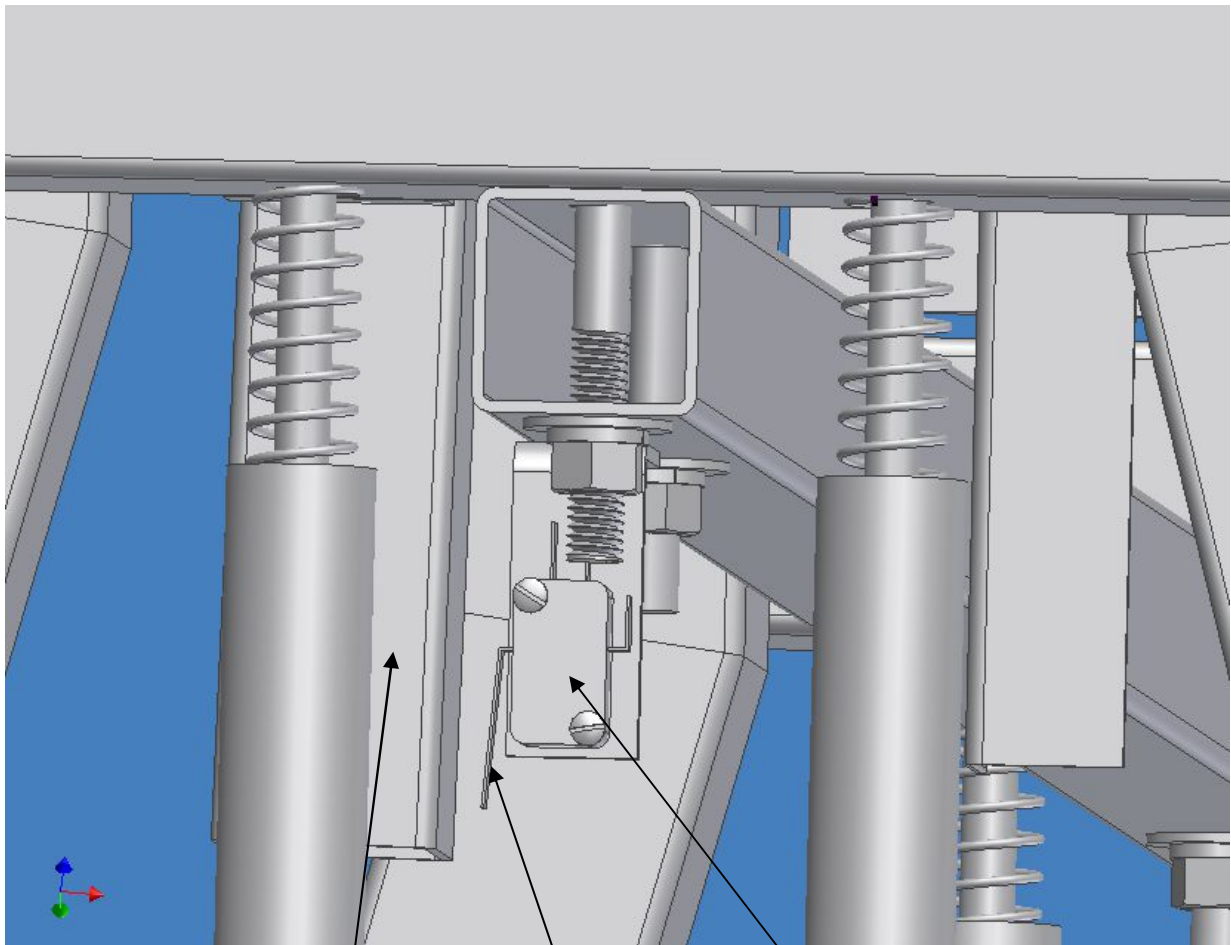

ACTUATOR. MICROSWITCH-ARM. MICROSWITCH

This view is of right channel-frame bottom. Some parts are left out to improve clarity.

## M4 TREADWALL Reed Switch Adjustment

The Treadwall counter-timer is controlled by a magnetic proximity switch (reed switch). On the M4 switch is located on the inside of the right channel near the drive chain in a pre-installed nylon clip. You will need to remove one climbing panel to gain access to this assembly.

- 1) The reed switch is pre-installed in a nylon clip on the sliding plate. The sensor can be adjusted by slipping it up and down in the clip:



- 2) Two magnets are positioned at the base of the sprocket so that they pass about 1/8" away from the reed switch. They are held in place by their own magnetism and super glue applied at the factory.



## **Treadwall® Service Sheet**

### **PAINTING YOUR TREADWALL®**

The Treadwall's come in a number of color configurations. They are designed to be easily touched up with locally available paint or paint available from Brewer's Ledge.

#### **Panels:**

Charcoal: Mix of ½ " Battleship Gray" – ½ "Black"  
(M6) Latex Acrylic Urethane floor enamel.  
Water based, applied with roller  
Use any matching latex for touchup, no need to be urethane reinforced  
Full repaint: gallon containers can be ordered from Brewer's Ledge

#### **Frames:**

White: Use any compatible white enamel  
(PE) Toyota auto #3223 is very good

Silver:  
(M6/Kore/M4) Toyota Galaxy Silver metal 12 WA519F

Beige: Use any compatible beige enamel  
(M4 older) Touch-up bottles available from Brewer's Ledge

See Treadwall Accessory Sheet for prices

## MAINTENANCE SCHEDULE

<b>ITEM</b>	<b>FREQUENCY</b>	<b>COMMENTS</b>
Adjust drive chain	After 2 weeks, then every 6 months	See page 2 Chain stretches during initial break-in period.
Clean climbing surface	Daily, or as needed	
Clean holds and alter climbing routes.	10 at a time every 2 weeks to one month as needed.	See page 1 Heavy usage = more cleaning Having 10 extra holds simplifies this process.
Wax panel ends	As needed – 6 months to 1 year.	Needed less frequently with time and use.
Paint climbing surface	Yearly, as needed	See page 1

## TREADWALL® LIMITED WARRANTY - All Models

### 1. WHO IS COVERED?

The original purchaser of any model Treadwall ("Original Purchaser") may only enforce this warranty.

### 2. ORIGINAL PURCHASER OBLIGATIONS

- a. The Original Purchaser assumes full responsibility that this Treadwall purchased meets the specifications, capacity and other requirements of the Customer.
- b. The Original Purchaser assumes full responsibility for the condition and effectiveness of the operating environment in which the Treadwall is to function including spatial considerations.

### 3. HOW LONG IS THE WARRANTY?

According to the following schedule, Brewer's Ledge Inc. warrants to the Original Purchaser of its Treadwall that under normal maintenance the Treadwall will be free from any defect in materials or workmanship.

#### For M4, M6, Kore Commercial models:

##### Structural Steel Frames and Welds:

Ten years - parts and labor and freight.

##### All other components except cords, floor mats and vinyl products:

One year - parts, labor, and freight.

##### Cords, side covers, floor mats:

Ninety days - parts, labor, and freight.

#### For KORE Home/Residential models:

##### Structural Steel Frames and Welds:

One year - parts and freight.

##### All other components except cords, floor mats and vinyl products:

One year - parts and freight.

##### Side covers, floor mats:

Ninety days - parts, labor, and freight.

### 4. WHEN DOES THE WARRANTY BEGIN?

Warranty begins from date of delivery to Original Purchaser or date of installation in the case of factory assembly. In the case of either Demonstration or Trial Agreement and related purchase, the warranty begins from the date of the original delivery.

### 5. WHAT IS NOT COVERED

- a. Normal wear and tear is excluded from this warranty. No warranty shall be provided in the event the Treadwall is modified by original purchaser, for parts not approved by Brewer's Ledge Inc., or for warranty-related service other than by personnel authorized by Brewer's Ledge Inc.
- b. Damage incurred by negligence during movement, assembly, or breakdown of the Treadwall by the Original Purchaser or personnel contracted by the Original Purchaser is excluded from this warranty. The sale of special tools and instructional materials to the Original Purchaser and any training of the Original Purchaser's staff by Brewer's Ledge Inc. related to the movement, assembly and break-down of the Treadwall does not imply any warranty against Original Purchaser negligence and does not void this exclusion. Brewer's Ledge Inc. reserves the sole right to determine the origin of damage as related to this provision.

### 6. LIMITATION OF DAMAGES AND IMPLIED WARRANTIES

- a. Except as provided herein, Brewer's Ledge Inc. makes no express warranties; implied warranty of merchantability or fitness for a particular purpose is limited in its duration to the duration of the written limited warranties set forth herein.
- b. In no case shall Brewer's Ledge be liable for any special, incidental, or consequential damages based on breach of warranty, breach of contract, negligence or any other legal theory. Such damages include but are not limited to, loss of profits, loss of use of the equipment or any associated equipment, the cost of capital, the cost of substitute equipment, facilities or services, downtime, the claims of third parties, including customers, and injury to property.  
This limitation does not apply to claims for personal injury where such limitation would be a violation of the applicable law. Some states do not allow the exclusion or limitation of incidental or consequential damages, so the above limitation or exclusion may not apply to you.

### 7. TERMS OF WARRANTY

The terms and conditions of this warranty are applicable as between Brewer's Ledge and Original Purchaser to the sale of Treadwall equipment to Original Purchaser.

### 8. STATE LAW RIGHTS

This warranty gives you specific legal rights, and you may also have other rights, which vary, from state to state.

Copyright 2007, Brewer's Ledge Inc.



# TREADWALL® M4-V Install Manual

The manual is arranged as a checklist. As you go through we encourage you to check off the steps. The Treadwall is a large, but not complicated machine. None of the steps in this manual are particularly difficult, but it is important to follow all of the steps carefully. *The order of assembly is important at certain points, so read each page.*

The drawings in the manual clarify some of the trickier points. We suggest you review them before you begin. Some of the photos are of the M6 however the procedures are the same.

**NOTE:** *There have been some substantial design changes since this manual was written: The hydraulic system is now mounted higher and both the display and new speed lever (pre-mounted) are now separate and located lower.*

**IMPORTANT:** *The transformer is designed for use with 110-220 volt 60 or 50 cycle AC current. It supplies 9 volts DC at 1.5 amps to the Treadwall. This is for the display and auto stop only. International customers may have to use a plug local adaptor.*

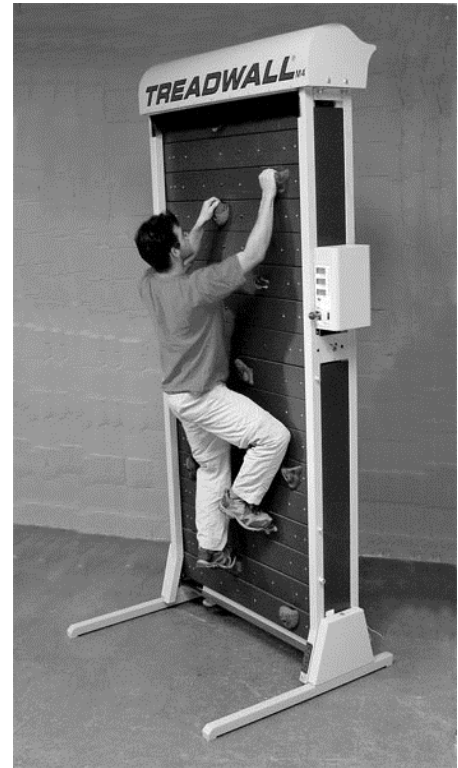

## **Requirements:**

Treadwall installation is a full day's work for two people. The installers should have mechanical aptitude and some experience with mechanical assembly. One Stepladder six-foot and sturdy is required. If you don't have one, rent it!

## **Other tools:**

VSR Electric drill with bits (and extension cord if it is not cordless)  
Combination wrench set - particularly the sizes 3/8", 9/16", 3/4".  
Socket wrench set - particularly the sizes 3/8", 9/16", 3/4".

Hammer	8" crescent wrench
Screwdrivers	Tape measure
Work gloves	Allen wrench set
Pair of pliers with nippers	2 carpenter's aprons
Knife	Eye protection
Vice-grip pliers	Spray cleaner and rags
Hand cleaner	
A couple of short (3-5 foot) pieces of 2x4 wood and some misc. blocks	

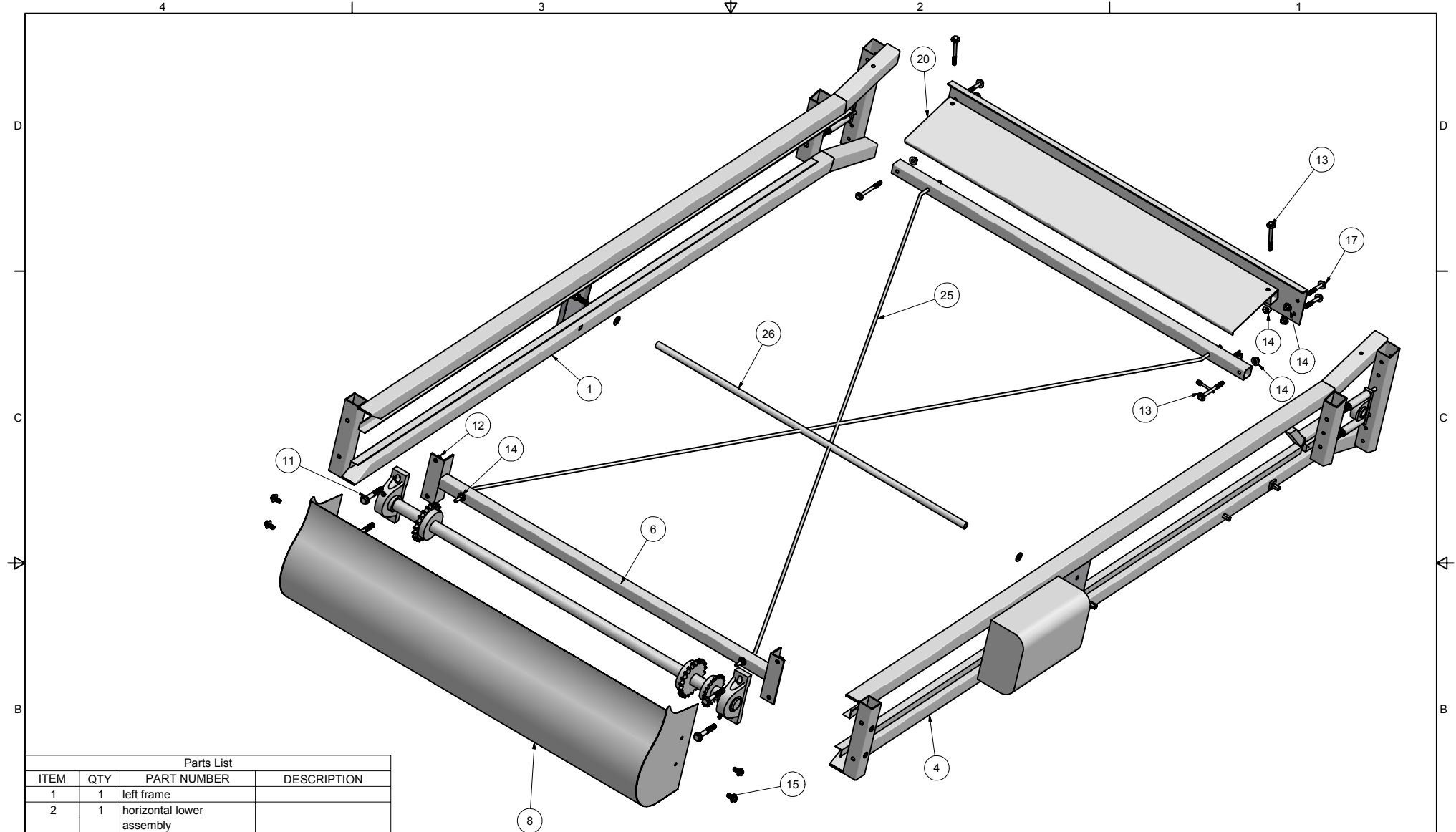

Parts List

ITEM	QTY	PART NUMBER	DESCRIPTION
1	1		left frame
2	1		horizontal lower assembly
4	1		right frame
5	1		lower shaft assembly
7	1		upper shaft assembly
8	1		shroud
11	4		bolt 1/2 x 3 1/2 with washer
12	4		nut 1/2 with lockwasher and washer
13	4		bolt 3/8 x 4 1/2 with washer
14	12		nut 3/8 with lockwasher and washer
15	4		bolt 3/8 x 1 with lockwasher and washer
17	4		bolt 3/8 x 3 with washer
18	1		back-guard
25	2		x brace inside
26	1		spacer tube

DRAWN Jeff	1/7/2007	Brewer's Ledge Inc.	
CHECKED		TITLE	
QA		Treadwall MODEL M Frame assembly	
MFG		frame with shroud explosion 3	
APPROVED		SIZE C	REV
		SCALE	SHEET 1 OF 1



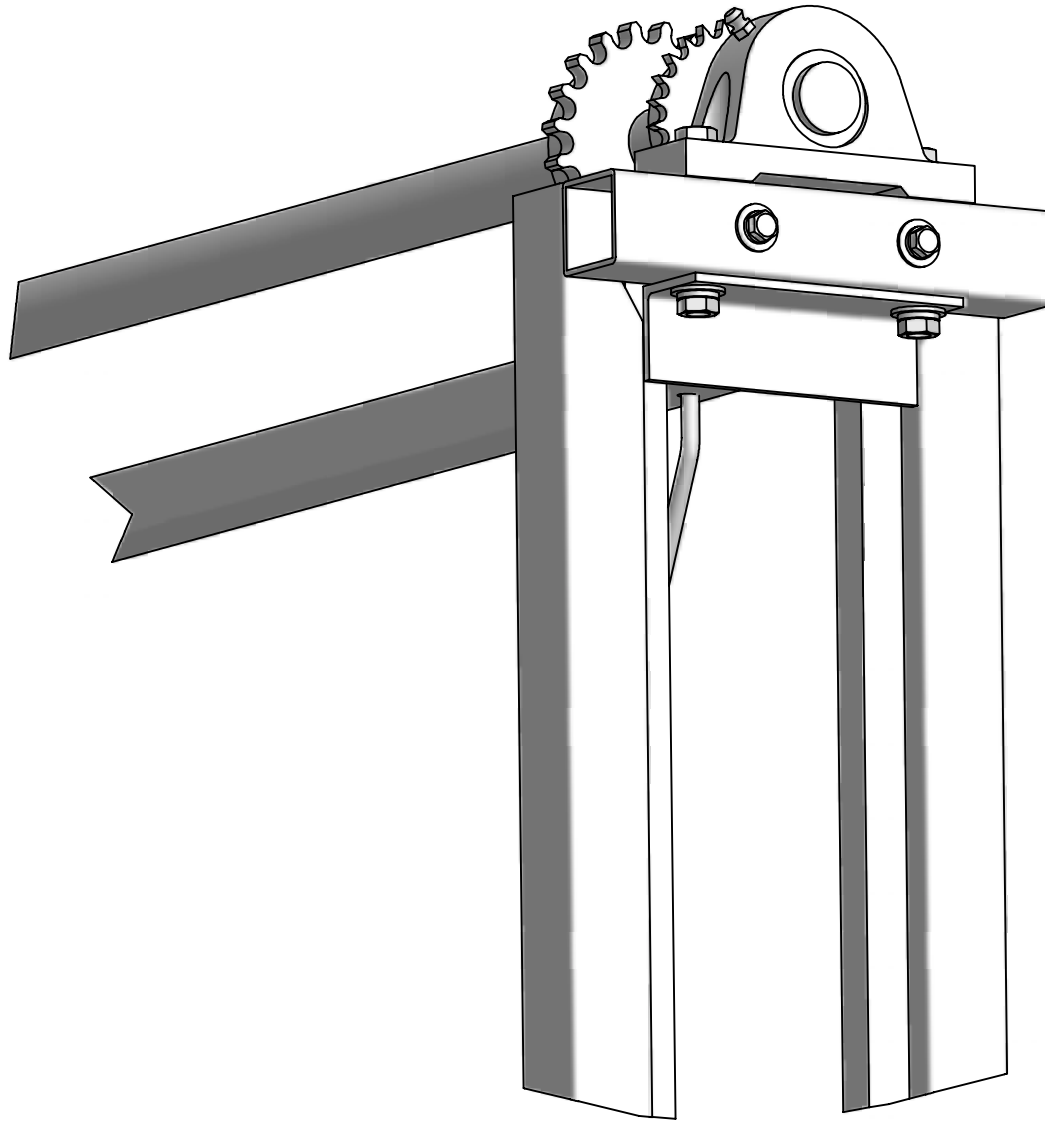

DRAWN Jeff	1/12/2007	Brewer's Ledge Inc.	
CHECKED		TITLE	
QA		M4 upper right frame detail	
MFG		SIZE	DWG NO
APPROVED		C	M4 top right detail
		SCALE	SHEET 1 OF 1

4

3

2

1

D

D

C

C

B

B

A

A

4

3

2

1

Actuator lever

NOTE: Three washers under this bolt head - both sides

Microswitch.  
Attach wires to terminals A and B.

Actuator lever swivels back and activates microswitch.  
After assembly, microswitch lever must be carefully bent  
(use needle-nose pliers) so that the actuator activates  
switch at approximately 1/2 of its travel.

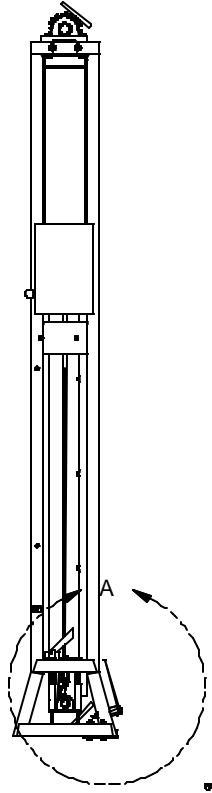

DRAWN Jeff	1/12/2007	Brewer's Ledge Inc.	
CHECKED		TITLE	
QA		M4 Actuator detail	
MFG		SIZE	DWG NO
APPROVED		C	M4-Actuator detail
		SCALE	REV
			SHEET 1 OF 1

## **Setup and unpacking:**

**Set up a neat and organized workspace.** It makes the whole job more pleasant and contributes to safety. Remove the packing materials from the work area – you will be working with ladders.

You should have some sort of table-high surface to put tools and small parts on where they will be easy to find and out of the way. In addition you will need a long space out of the way where you can lay out all the long parts.

The panels go on last, so put them to one side until needed.

- ❑ **Remove wrapping** from large parts being careful not to damage the surfaces. Take small parts out and unwrap them. Don't unwrap the rock holds until the end.

**Check the parts against the list**, and look them over for shipping damage. ***You must make damage claims within 10 days of delivery***

The panels go on last, *put them aside* along with the metal reinforcing bars (“stiffies”) and handholds until needed. You will also need a space big enough to lay out the long parts.

***All references to “right”, “left”, “downwards”, etc refer to the finished unit as viewed from the front.***

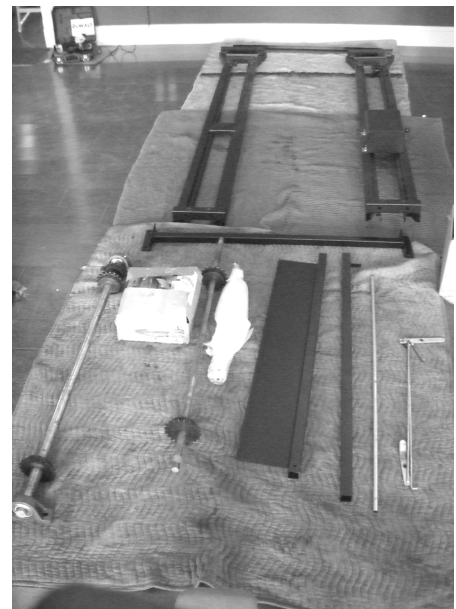

## Frame assembly:

Refer to the drawings at left and on next page to make sure you are orienting all parts correctly.

The M4 has two channel-frames and various shafts and horizontals that connect them together. You assemble it face down on the ground, and lift it into position.

The right frame is the one with the control panel box pre-mounted.

Assemble starting from the top – the top shaft and top horizontal member - and work down. *Leave bolts loose until the entire assembly is complete – then go back and do the final tightening.*

- ❑ **Lay down the two channel frames.** There are channels on the inside of each frame that will guide the climbing panels. Lay the channel frames on their edges with these channels facing towards each other, about 4 feet apart. The bottom ends of the channel frames (“flared”) should be centered inside the assembled support frame.

Prop up the channels on blankets or 2x4 blocks so that the narrower top end is off the ground, *The ball valve handle should not be touching the ground.*

## Main Shaft

The main shaft has four bearings and three sprockets. **The end with two sprockets goes to the right.**

- ❑ **The upper Horizontal** (with the “tee” ends) is bolted-on along with the upper shaft. **VERY IMPORTANT: The ends are oriented with the flange down – see the drawing on the next page.**

ALSO IMPORTANT: The tee end of this horizontal will not fit through the opening in the channel-frame without twisting it 90 degrees. Make sure that both tee ends are in place in the channel frames and aligned before attaching either side. Use “D” bolts ( $\frac{1}{2}$ ” x 4”) each side.

Leave the bolts somewhat loose.

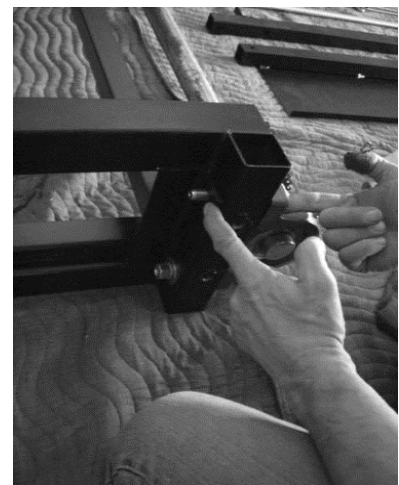
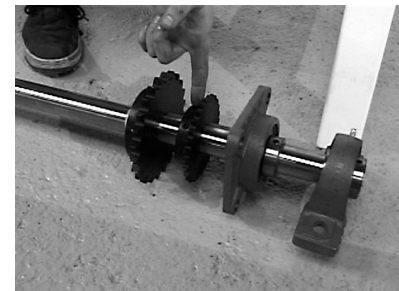

- **Install the spacer tube** onto the two studs found in the middle of the channels. This tube maintains spacing in the mid-section. It will be adjusted later. The hollow ends of the tube fit over each stud. (Image shows x-bracing which goes in later)

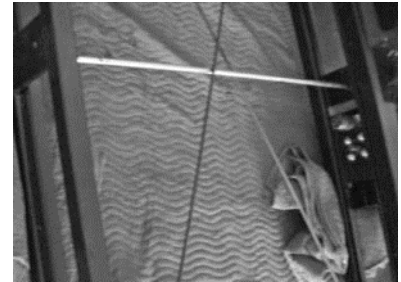

- **Slide the Bottom Axle** into the bottom bearings, which come pre-mounted on the channels. Note shaft has one fixed sprocket and one free sprocket that is intentionally left loose to slide back and forth. The fixed sprocket goes to the **right**. Mount shaft in the bearings so the left stop collar (silvery rings) is against the bearing. Leave the ends of the shafts flush or just outside the bearings: you adjust these later.

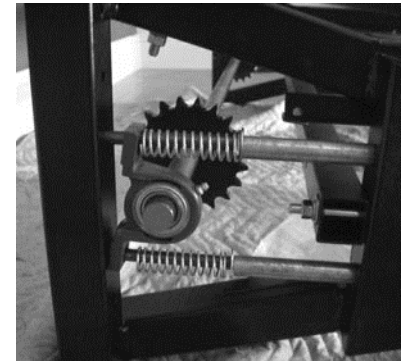
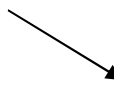

**There is one sliding sprocket on the bottom shaft: this goes to the right. It remains loose.**

- **Install the bottom horizontal** using “A” bolts (3/8” x 4 1/2”).



*NOTE: Extra washers are installed under the head of this bolt to raise the bolt up higher. There should be 3 washers under the head of the bolt (see drawing next page). Make sure the small tab with a switch is at the bottom of the bar and on the right side. Leave somewhat loose.*



- Attach the “bullet” connectors on the switch to the frame wire

- **Install the Rear Guard** using “A” bolts (3/8” x 4 1/2”), one each side. Leave somewhat loose.



- ❑ **Install the two internal cross-bracing rods.** These are long 3/8" rods that are threaded and bent each end. Insert each into holes in the lower horizontal. *Where they cross the spacer-tube in the middle of the wall, one rod should go under and one should go over the tube so that the tube is in-between the rods.*

- ❑ **Insert them into upper horizontal** by flexing the rods slightly, Assemble with nuts and washers.

- ❑ **Tighten** so that threads showing at all ends are approximately even, bottom and top as well as side to side. Do not over-tighten – firm but not hard.

- ❑ **Tighten** all the bolts you have installed. Tighten firmly, but not enough to distort the frame tubing.

- ❑ **Mount the Top Shroud** onto the top of the channels. There are (4) 3/8" x 1" bolts that go into threaded inserts on each side. Tighten. The logo should be facing down (front of the Treadwall).

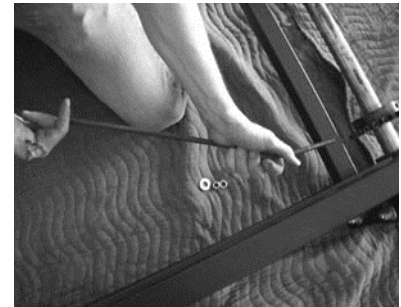

## ***Lifting the Core into place***

- **Place blocks of 2x4 wood at least 24” long under the bottom of the channel frames.** These should extend out so that when the assembly is tilted upright, the foot of each channel frame is resting entirely on the blocks – 1 ½” above the floor level.

***Use three persons to lift up the core into standing position!***



- **Lift up the core Assembly.** Make sure it is centered well on the wood blocks. **Make sure one person supports the assembly at all times until it is secured to the feet.**



- **Raise one side of the core assembly and slip the foot unit underneath** – substituting it for the wooden block. The beveled end of the foot unit goes towards the front of the Treadwall. Line up the mounting holes and bolt on the foot unit with “**A**” bolts (3/8” x 4½”), with washers and lockwashers. Repeat for the other side.

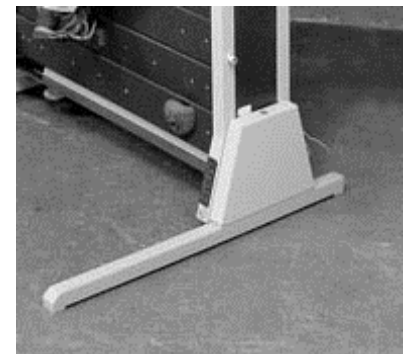

## Installing the Drive Chain

The *drive chain* connects the pump with the main shaft. It controls the wall speed.

- ❑ **Install the #40 drive chain** between the pump and the sprocket on the upper shaft. Drape it over the top sprocket and around the pump sprocket. Connect the ends with the master link. The chain will seem very loose at this point.

The pump unit should be in its highest position to allow the Drive Chain to reach around the lower sprocket. It is mounted this way at the factory, but can slide down a bit, so check and correct if needed..

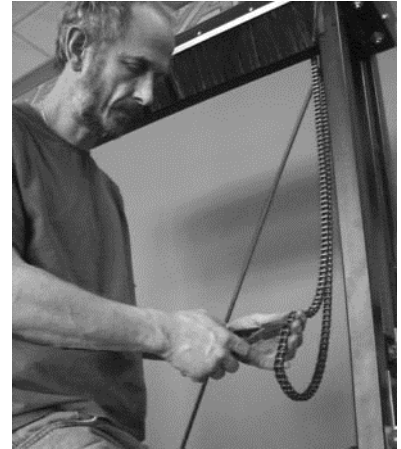

- ❑ **Open the hinged control panel** by removing the small screw that holds it closed (don't lose the little screw!). Above the pump you will find a long "tensioning" bolt that is used to adjust the chain.

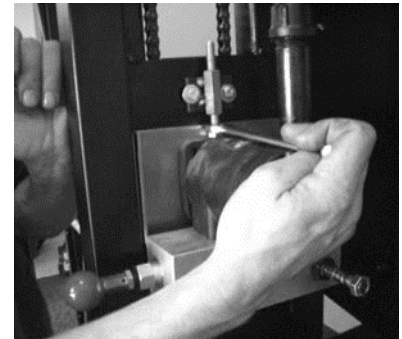

- ❑ **Use the tensioning bolt** to push down the pump until the slack is removed from the drive chain. If this chain is too tight, the Treadwall will not work properly. Just take out the slack, but do not make the chain "bar tight".  
**Important** - This chain will stretch during installation and the first two weeks of use and require adjustment.



## ASSEMBLING MAIN CHAINS

Each Treadwall main chain come in two boxes that must be assembled to a full length chain using a masterlink.

If the boxes are marked "short" and "long", use one short and one long for each chain. If the boxes are unmarked, use any two boxes to make each chain.

Note that the ends of the chains are different as shown below. Attach the end of chain A with a single extra link to the end of chain B that has five links. This will insure that the spacing between the chain tabs is correct and uniform.

Also, make sure that the tabs are all facing the same direction as in the picture.  
The masterlinks are located at one end of each length of chain.

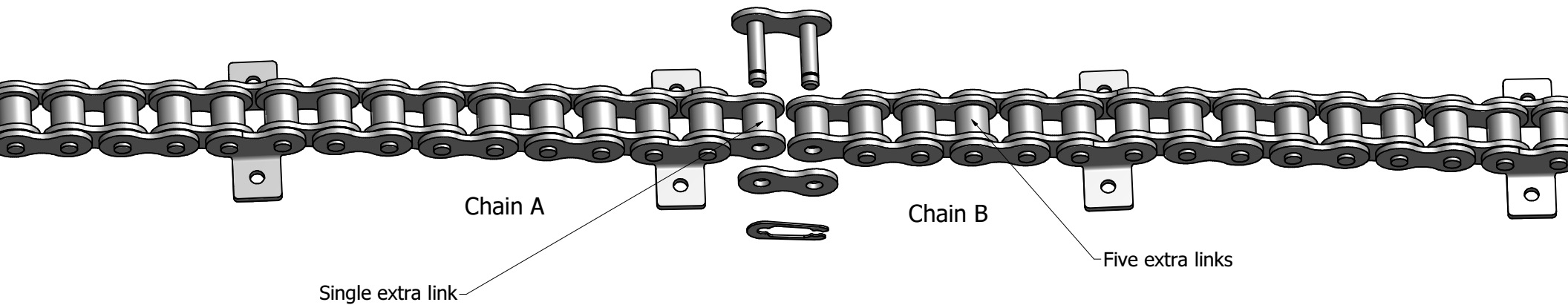

Brewer's Ledge Inc.  
800-707-9616  
[www.treadwall.com](http://www.treadwall.com)

CHAIN ASSEMBLY DRAWING REV .1  
6-11-14

## The Proximity Switch

- ❑ The *proximity switch* sensor controls the counter-timer. It is pre-mounted onto the channel with the magnets attached in place on the sprocket. The sensor wire is pre installed ready to mount into the back of the display. See the service manual for adjustment if needed.



## The Main Chains:

- ❑ **Remove the chains from one box (there are two).** The *main chains* are coiled and have mounting tabs for the panels. Each chain comes in two sections and is joined together before installing. See the important instructions on the next page.

- ❑ One person should hold the completed chain on edge and unwind it while the other raises the chain over the shaft. Wear gloves and protect the floor with a piece of cardboard or blanket.

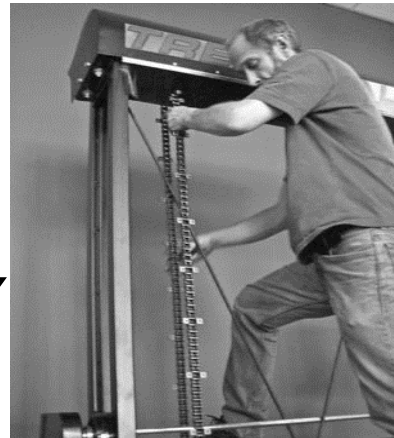

- ❑ **Lift one chain** up to the main shaft and drape it over the shaft next to one of the sprockets.

*Make sure the chain tabs are facing out!*

- ❑ **Move the chain around** the shaft until the two ends are equal at the bottom.
- ❑ **Lift the chain** onto the top sprocket.
- ❑ **Pry up the lower shaft at this end** using a length of 2x4. You can slip the 2x4 under the shaft and hook it over the back-guard support to lift the shaft up enough to attach the chain.
- ❑ **Attach the ends of the chain together** under the sprocket using the master link on the chain.



The spring clip should be on the inner side of the chain – this helps to locate the master link if you need to find it later.

The second chain is installed the same as the first, but during installation of the second chain, perform the all-important synchronization step:

- **Adjust both chains until they are synchronized.** Before attaching the second master link, line up one of the chain tabs on each chain with the horizontal spacer tube. Check that the two tabs are aligned with the each other against the spacer tube. If the tabs don't line up, adjust the second chain until they do.

***The chains must be synchronized so that the tabs are directly across from each other. If the synchronization is off by even one sprocket-tooth the Treadwall will not operate.***

Later in the installation, if you find that the synchronization is off, give us a call. We have a quick fix.

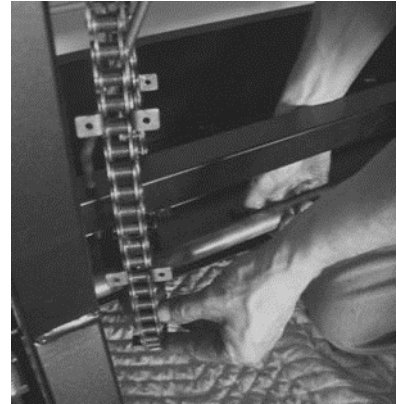
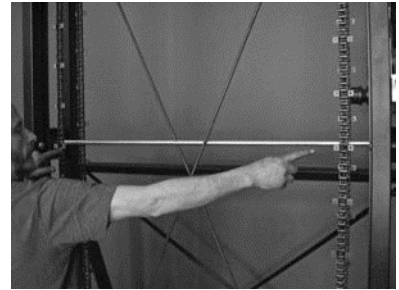

- The display on the M4-V is mounted to the right channel and attached with four bolts to the outside of the speed lever box. You will have to remove the cover to install. A flexible arm holds the display – adjust as needed. You will run the power wire and the sensor wires out of the channel under the black side cover (these are put on at the end) and plug both wires into the back of the display. The two plugs are different.

## Installing the Panels

Putting on the *panels* is a tedious job, but it goes better if you are organized and have the basic tools.

You will need a 3/8" socket wrench and a battery-operated drill with an adjustable clutch fitted with a #2 Phillips bit. A carpenter's apron to hold the bolts and nuts is very helpful.

- ❑ **Install a reinforcing channel (“stiffy”)** onto the back of each panel before bolting to the chains. The stiffy slips into the holes when properly aligned. If the stiffy is a tight fit, you can place the panel face down on the floor and step on the stiffy to push it into place.

- ❑ **Attach the stiffy to the panel** There is a bag of short round-head bolts in the hardware box. Screw in one of these bolts to hold on the stiffy. Notice on the front of the panel that there are three equally spaced holes near the center. We like to attach this bolt to the middle of these holes.



- ❑ **Adjust the spacer tube.** There should be enough space between the channel-frames so that a climbing panel can be put into the channels diagonally and rotated to a horizontal position without binding. The panels may bind because the channel-frames bow in slightly. The spacer tube must be adjusted to compensate. Turn out the nuts at the ends of the spacer tube to push the channel-frames apart until the panels can be placed without binding. Adjust equally from each end.

- ❑ **Slip the first panels into the front of the channels.** If you have trouble rotating them down into the horizontal position, read the previous paragraph. (M6 shown)



- ❑ **Bolt the panel on.** The nuts go to the rear. Make the bolts firm, but not tight enough to sink the heads into the panels. Use a very low setting (typically 3-5) on the drill clutch.

- ❑ **Rotate the first panel around by pulling the chains down until the panel has made one complete rotation.** This will align the sliding sprocket on the bottom shaft. You may have to tap the sprocket into alignment with a hammer. (image to right is model PE for illustration only)

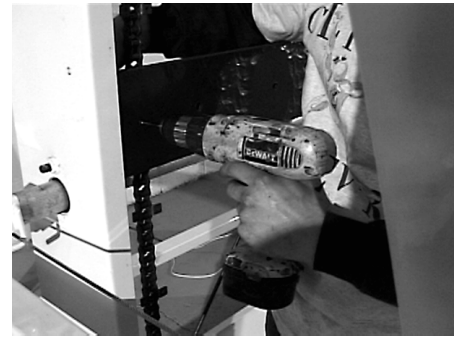

- ❑ **Check the panel** at the bottom of the machine to make sure it is centered. There should be @ 1/4" gap at each end. Do the final adjustments on the shaft until the panel is centered and tighten the bottom bearing setscrews then you can make sure both stop collars are out against the inside of the bearings. Re-tighten.

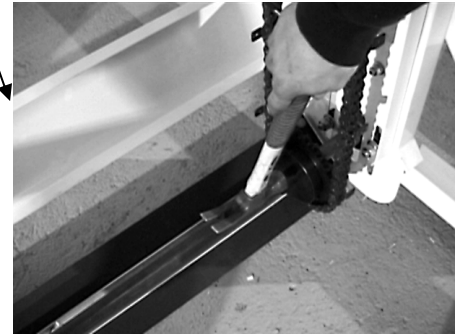

**Check the display while you are rotating this first panel.** Plug in the transformer and connect the wires at the back of the right Angle Support Frame. The display should come on. As you rotate the wall, the "distance" count should reflect the movement. Adjust the sensor if needed.

**IMPORTANT:** *The Treadwall transformer is designed for use with 110 volt 60 or 50 cycle AC current. It supplies 12 volts DC at 1.5 amps to the Treadwall. Users with different supply voltages must use a conversion transformer or other means to provide the proper voltage.*

- ❑ **Connect and adjust the actuator switch.** The small microswitch at the bottom of the right channel runs the braking system for the wall (see drawing at end of manual). Attach the two "bullet" connectors on the frame wire to the switch if you have not done this earlier. The hinged "actuator" at the bottom of the channel pushes the switch, and when you push this actuator in, you should hear a "click" in the switch.

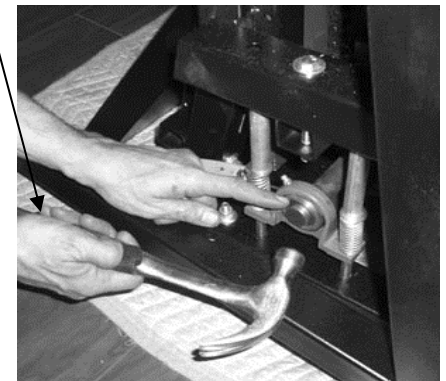

If necessary, you should adjust the switch by carefully bending the small arm on the switch with a pair of needle-nose pliers until it clicks when the actuator is pushed about 2/3 of the way in.



- ❑ **Alternate the panels.** The holes are not symmetrical. During installation every other panel should be turned over so that the holes alternate from side to side.

As you progress, and the panels are moving up the back of the machine, it normally takes a bit of effort to push the front panels down. You will need to lock the front panels to keep them from back sliding up.



**Use short pieces (12" or so) of 2x3 lumber to lock the wall at the bottom.**

Simply slip them into the space between panels at each end of the bottom of the wall. As the panels try to ride up, the blocking will jam between two panels and hold the wall in place while you work. (M6 shown)



- ❑ **Bolt on the panels** until there is only one left. The last three panels are installed by slipping them in from the bottom. Rotate the panels around until the gap is at the bottom front. Slip in the panels one at a time and install the bolts. Use the side openings to access the nuts for tightening.

- ❑ **Adjust the internal x-bracing** one more time to make sure it is even and tight.

- ❑ The last panel is somewhat awkward - be patient. Put the bolts and nuts in with the panel at the bottom or carefully rotate the panel upward until you can reach the nuts through the side.

## ***Installing the side covers and bottom covers***

The sheet metal bottom covers simply slip over the bottom bearings and lock into place.

There are four side panels that cover the gaps in the Channel frames. Velcro tabs hold the covers in place. The chamfer on the covers face inward to provide clearance for the welds in the frame opening.



## ***Mounting the Holds***

The standard Treadwall hold set has 30 holds of four different colors and a set of LadderLine™ holds which should be installed first. Instructions are packed in the LadderLine box.

- ❑ **Unpack all the holds** and lay them out on the mat in front of the machine.
- ❑ **Match the holds with hold-bolts.** The bolt should project at least 1" from the back of the hold. A few of the larger holds need longer bolts.
- ❑ **Bolt the holds** firmly onto the panels. Never force a bolt into the threaded insert. The insert can be damaged if the bolt is cross-threaded.

Start with one color and bolt one hold onto each 4th or fifth panel. Distribute them evenly from side to side as you go along. Repeat for each color, distributing evenly to prevent any blank areas.



Each hold has a positive edge. Generally speaking, these positive edges should face up so that the climb will not be too intimidating, but put a few on as side-grips or under-clings to add interest. Once the holds are on you can fine-tune it by rotating holds and moving a few around.

Each color of holds can be a separate climbing route. Or you can combine colors to make a route. You will find that some routes are much easier than others.

**Very important - Don't allow larger holds to overlap onto the next panel.** The majority of holds supplied with the Treadwall are designed so that they cannot overlap, but other holds may be larger. Also, holds must not stick out more than 2 ½" from surface of wall.



### ***Purging the Hydraulic System:***

Sometimes when the Treadwall is first assembled, the control system runs a bit rough and noisy - almost a grinding sound - and the wall doesn't descend smoothly. This is due to air in the system that foams into the oil and causes cavitation in the pump. To purge the air, put the wall at the steepest angle, set the cardio dial at the fastest setting, and pull the wall around steadily for about 15 seconds. Let the wall sit for about 5 - 10 minutes, and do it again. If you do this about 3 times, the air will percolate up into the reservoir where it belongs, and the wall will run smoothly.

### ***Mat:***

The mat fits between the two Bottom supports and under the rotating wall.

### ***Test climb:***

Test the finished Treadwall by climbing for at least 200 feet. Newly installed Treadwalls will usually run a bit rough because of air in the hydraulic system. When this air has left the oil - usually after a few climbing sessions - the resistance is much smoother. Other than this normal breaking-in, the wall should operate quietly without any binding or other impediments.

The drive chain should be checked one more time (it stretches at first), and should be re-checked after a couple of weeks of service. Make sure someone on-site knows how to adjust this chain.

Check holds for tightness and re-tighten. Adjust any holds that seem awkward or out-of-place.





The last word:

## NOBODY LIKES GOING BACK!

Treadwalls get installed in the strangest places, sometimes hundreds of miles from where installers call home. Making that long trip across the panhandle and down through the wastelands to fix some little problem is a project best avoided.

It's the little things that count - at least that is what we have found. Those little tiresome details have a tendency to sneak around to your backside and take a big bite. Here are some things that have shown up on the whack-your-head-and-say-"duh" film clips (and which we have *all* done at one time...):

### 9 Master link or Monster link?

Every master link has three parts. What if you leave off the plate with two holes? What if the spring clip isn't put on right? It can get pretty ugly!

### 9 What the heck is our display showing?

Time? Distance? Dow Jones average? Whatever. It isn't gonna work if the sensor and magnets aren't adjusted right. And treat that reed-switch sensor with respect! And make sure the wire is out of harm's way.

### 9 "Bolts and nuts are falling down\* falling down, falling down..."

And for some reason the shroud only has one bolt on the right side!  
Yes - it's actually happened. Loss of concentration is my guess.  
*Check everything before putting on the last panels. Take your time.*

### 9 "Chain-chain-chain chains that fool..."

Drive Chain too tight? Works great for Ralph but Alice can't budge it. Too loose? Could be worse. Take out all the slack, but don't over-tighten. Check it one last time before leaving, and *make sure someone knows how to adjust it!*

### 9 "Setscrews and turnbuckles--lockwashers, jam nuts...these are a few of my least favorite things!"

Especially when they aren't set, turned, locked and jammed. Just take a couple of minutes to go over those little details and save yourself a big headache.

Call us Brewer's Ledge if you have any questions. We can often answer a question in minutes that will save you much more time trying to understand. Please let us know any comments or suggestions you might have: we are always upgrading the materials as we learn more.

Hours: 9-5 E.S.T  
Telephone: 800-707-9616  
Email: [sale@treadwall.com](mailto:sale@treadwall.com)